

SCALE™-2 1SC0450E2B0

Preliminary Description & Application Manual

Single-Channel Cost-Effective Driver Core for IGBTs up to 4500V and 6500V

Abstract

The 1SC0450E2B0 single-channel SCALE™-2 driver core combines unrivalled compactness with broad applicability and cost-effectiveness. It is designed for industrial and traction applications requiring high reliability. The 1SC0450E2B0 drives all usual high-voltage IGBT modules up to 4500V and 6500V. Up to four parallel-connected IGBT modules can be driven to cover higher power ratings. Multi-level topologies involving 3300V or 4500V IGBTs with higher isolation requirements can also be easily supported by the 1SC0450E2B0.

The 1SC0450E2B0 supports maximal design flexibility as no fiber-optic links are assembled on the driver board. Gate drive input and output signals are provided over dedicated electrical interface connectors.

The 1SC0450E2B0 is the most compact driver core in its voltage and power range, featuring a footprint of only 60mm x 90mm and a maximum insertion height of 27.5mm. It allows even the most restricted insertion spaces to be efficiently used.

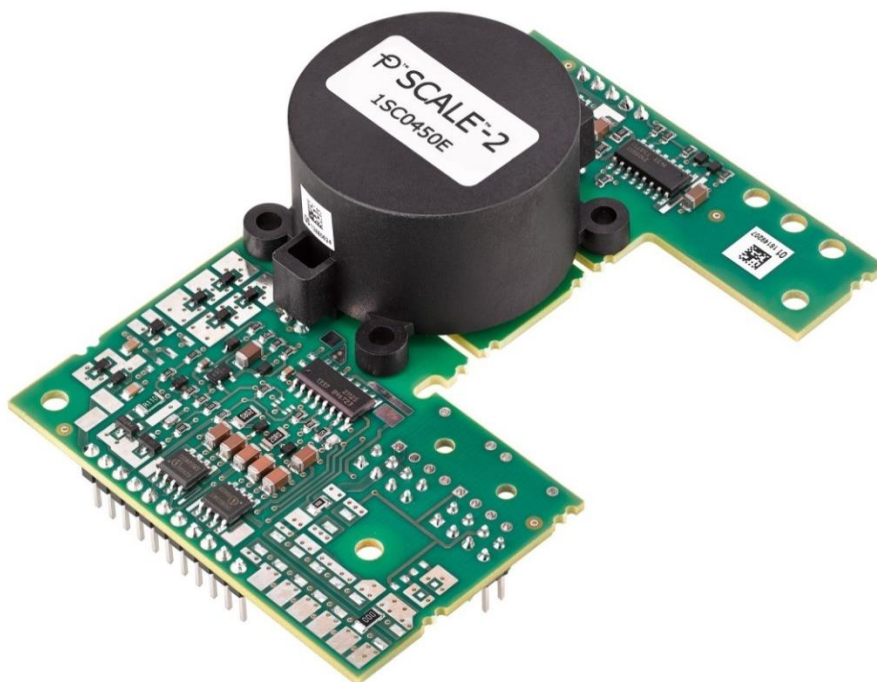

Fig. 1 1SC0450E2B0 driver core

Preliminary Description & Application Manual

Contents

Driver Overview	4
Mechanical Dimensions.....	5
Pin Designation	7
Recommended Interface Circuitry for the Primary-Side Connector.....	8
Description of Primary-Side Interface	8
General.....	8
VCC terminal	8
VDC terminal.....	8
GND	9
SO (status output).....	9
Recommended Interface Circuitry for the Secondary Side Connectors	9
Pins 6 to 16.....	9
Pins 17 to 32.....	10
Description of Secondary-Side Interfaces	10
General.....	10
DC/DC output (VISO), emitter (VE) and COM terminals.....	11
Reference terminal (REF)	11
Collector sense (VCE).....	11
Input for adjusting the turn-off delay in fault condition (CSHD)	14
Active Clamping (ACL).....	15
Gate turn-on (GH) and turn-off (GL) terminals	15
Gate Boosting Power Supply (VGB)	16
Gate Boosting Signal (GBS)	16
Gate Drive Input (IN).....	16
Status Feedback /Fault input (OUT)	16
How Do 1SC0450E2B0 SCALE-2 Drivers Work in Detail?	19
Power supply and electrical isolation	19
Power-supply monitoring.....	19
Parallel connection of IGBT modules	19
3-level or multilevel topologies.....	19
Gate Boosting.....	20
Bibliography	22
The Information Source: SCALE-2 Driver Data Sheets	23
Quite Special: Customized SCALE-2 Drivers	23
Technical Support	23
Quality	23
Legal Disclaimer	23

Preliminary Description & Application Manual

Ordering Information	24
Information about Other Products	24
Power Integrations Sales Offices	25

Preliminary Description & Application Manual

Driver Overview

The 1SC0450E2B0 is a driver core equipped with the latest SCALE-2 chipset from Power Integrations /1/. The SCALE-2 chipset comprises a set of application-specific integrated circuits (ASICs) that cover the main functions needed to design intelligent gate drivers. The SCALE-2 driver chipset is a further development of the proven SCALE™-1 technology /2/.

The 1SC0450E2B0 targets medium- and high-power IGBT applications up to 6500V. The driver supports switching frequencies up to 10kHz with best-in-class efficiency. The 1SC0450E2B0 comprises a complete single-channel IGBT driver core, fully equipped with an isolated DC/DC converter, electrical interface for the external use of fiber-optic transceivers, short-circuit protection, Advanced Active Clamping and supply-voltage monitoring. Additional features such as gate boosting are also implemented and provide further driving benefits.

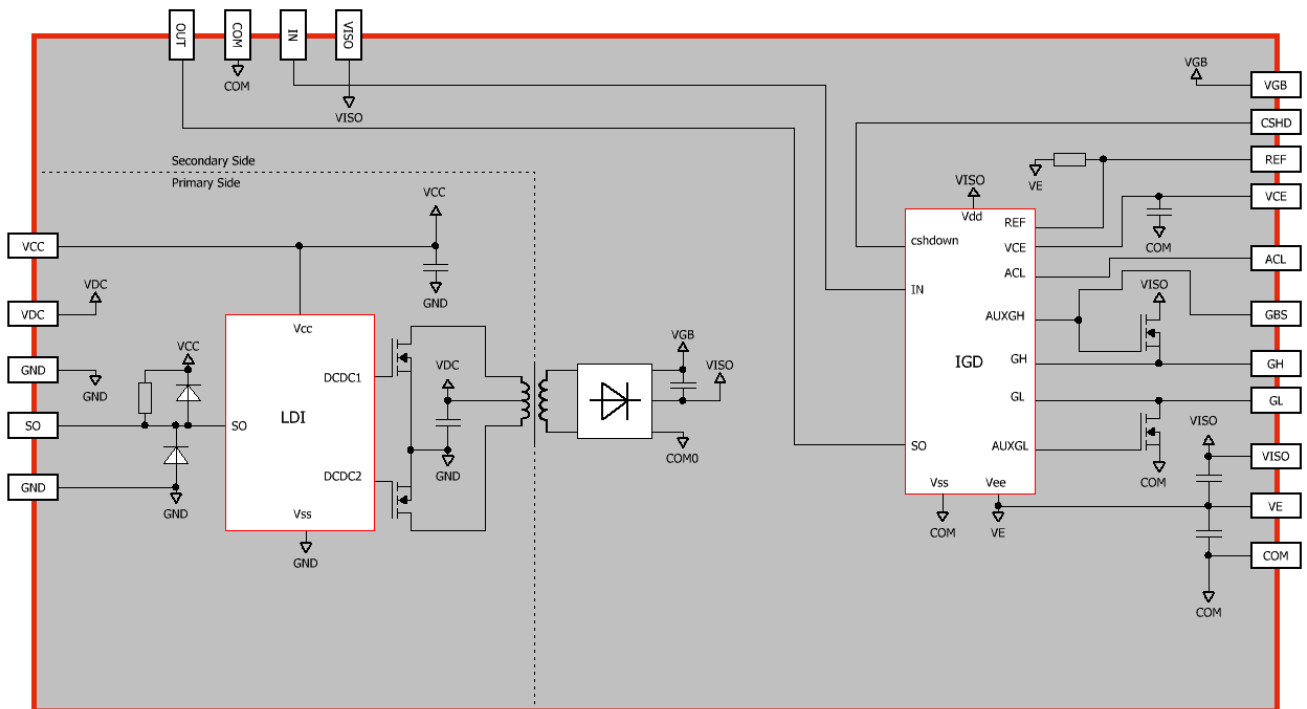

Fig. 2 Block diagram of the 1SC0450E2B0 driver core

Mechanical Dimensions

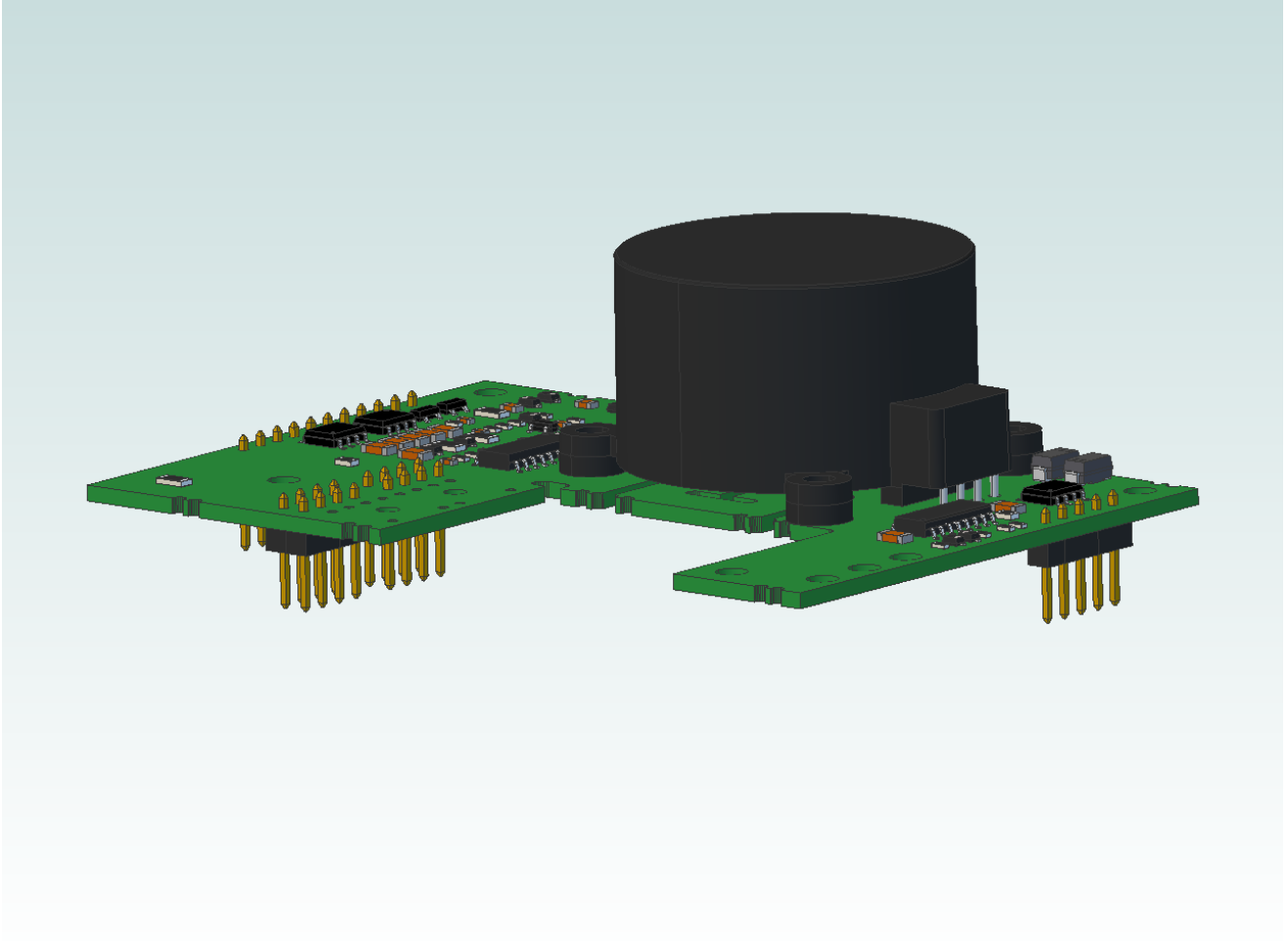

Fig. 3 Interactive 3D drawing of the 1SC0450E2B0

Preliminary Description & Application Manual

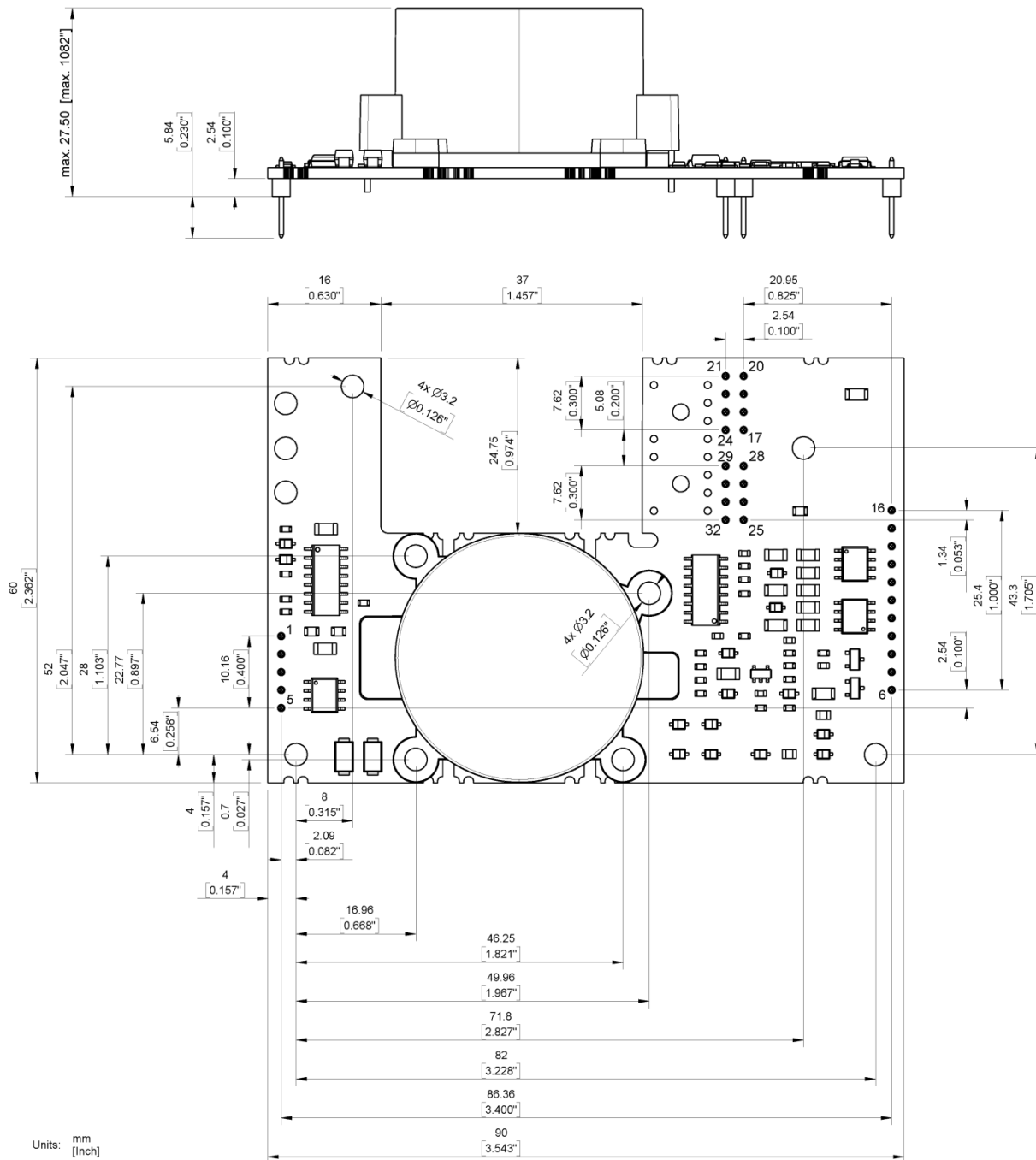

Fig. 4 Mechanical drawing of the 1SC0450E2B0

The primary-side and secondary-side pin grid is 2.54mm (100mil) with a pin cross-section of 0.64mm x 0.64mm. Total outline dimensions of the board are 60mm x 90mm. The total height of the driver is maximum 27.5mm measured from the bottom of the pin bodies to the top of the populated PCB.

Note that the mechanical fixing points are placed in the clearance and creepage paths. Insulated fixation material (screws, distance bolts) must therefore be used in order not to reduce these. The fixing points support M3 screw size.

Recommended diameter of solder pads: Ø 2mm (79mil)

Recommended diameter of drill holes: Ø 1mm (39mil)

Preliminary Description & Application Manual

Pin Designation

Pin No. and Name	Function
Primary Side	
1 SO	Status output primary side; normally pulled up to VCC over a 10kΩ resistor, pulled down to low in case of a fault
2 GND	Ground
3 VCC	Supply voltage; 15V supply for primary side
4 VDC	DC/DC converter supply
5 GND	Ground
Secondary Side	
6 VGB	Gate-boosting power supply
7 VISO	DC/DC output
8 COM	Secondary-side ground
9 CSHD	Set turn-off delay after fault detection; capacitor to COM
10 GH	Gate high; pulls gate high through turn-on resistor
11 GBS	Gate-boosting signal
12 VE	IGBT emitter
13 GL	Gate low; pulls gate low through turn-off resistor
14 ACL	Active clamping feedback; leave open if not used
15 REF	Set V_{CE} detection threshold through resistor to VE
16 VCE	V_{CE} sense; connect to IGBT collector through impedance network
17 COM	Secondary-side ground
18 VISO	DC/DC output
19 COM	Secondary-side ground
20 COM	Secondary-side ground
21 COM	Secondary-side ground
22 IN	Gate driving input; Inverted non-isolated signal input
23 COM	Secondary-side ground
24 COM	Secondary-side ground
25 COM	Secondary-side ground
26 OUT	Status output and external fault input
27 COM	Secondary-side ground
28 COM	Secondary-side ground
29 COM	Secondary-side ground
30 OUT	Status output and external fault input
31 OUT	Status output and external fault input
32 COM	Secondary-side ground

Preliminary Description & Application Manual

Recommended Interface Circuitry for the Primary-Side Connector

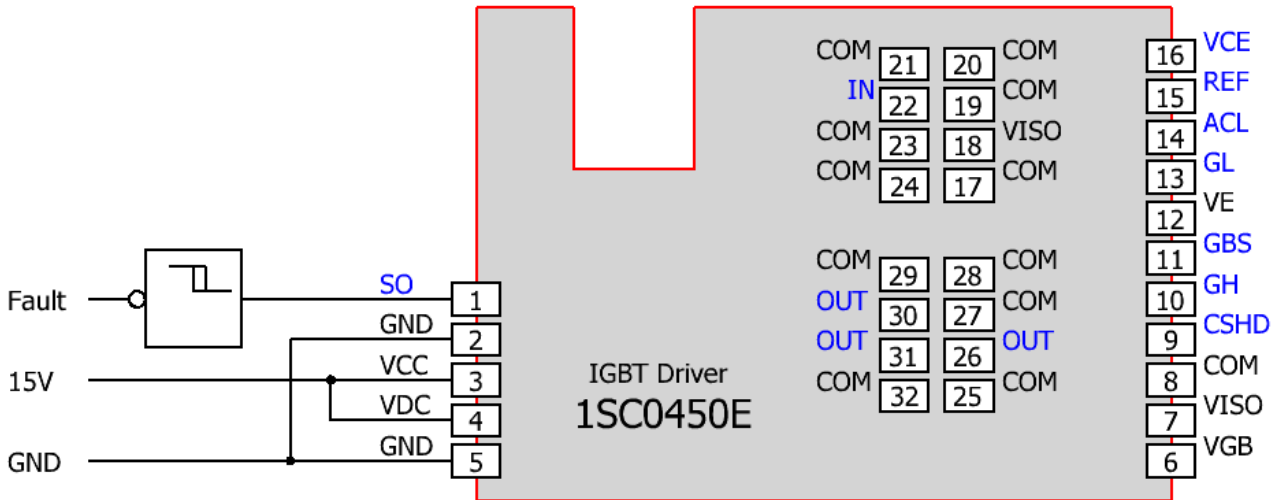

Fig. 5 Recommended user interface of the 1SC0450E2B0 (primary side)

Description of Primary-Side Interface

General

The primary-side interface of the 1SC0450E2B0 driver is very simple and easy to use. The driver primary side is equipped with a 5-pin interface connector with the following terminals:

- 2x power-supply terminals VCC and VDC
- 2x ground terminals GND
- 1x status output SO (indicating a fault during primary-side under-voltage)

All inputs and outputs are ESD-protected.

VCC terminal

The driver has one VCC terminal on the interface connector to supply the primary-side electronics with 15V.

VDC terminal

The driver has one VDC terminal on the interface connector to supply the DC/DC converter for the secondary side.

VDC should be supplied with 15V. It is recommended to connect the VCC and VDC terminals to a common 15V power supply. In that case, the driver limits the inrush current at startup and no external current limitation of the voltage source for VDC is needed.

Preliminary Description & Application Manual

GND

Both ground pins must be connected together with low parasitic inductance. A common ground plane is strongly recommended. Furthermore it is recommended to shield all primary-side circuitry with the ground plane. The connecting distance between the ground pins must be kept to a minimum.

SO (status output)

When no primary-side under-voltage condition is detected, an internal pull-up resistor of 10kΩ keeps the output level at the voltage level of VCC. When a primary-side supply under-voltage is detected, the status output SO goes to low (connected to GND). The SO output is automatically reset (returning to the voltage level of VCC) when the under-voltage on the primary side disappears.

The maximum SO current in a fault condition must not exceed the value specified in the driver data sheet /3/.

Recommended Interface Circuitry for the Secondary Side Connectors

Pins 6 to 16

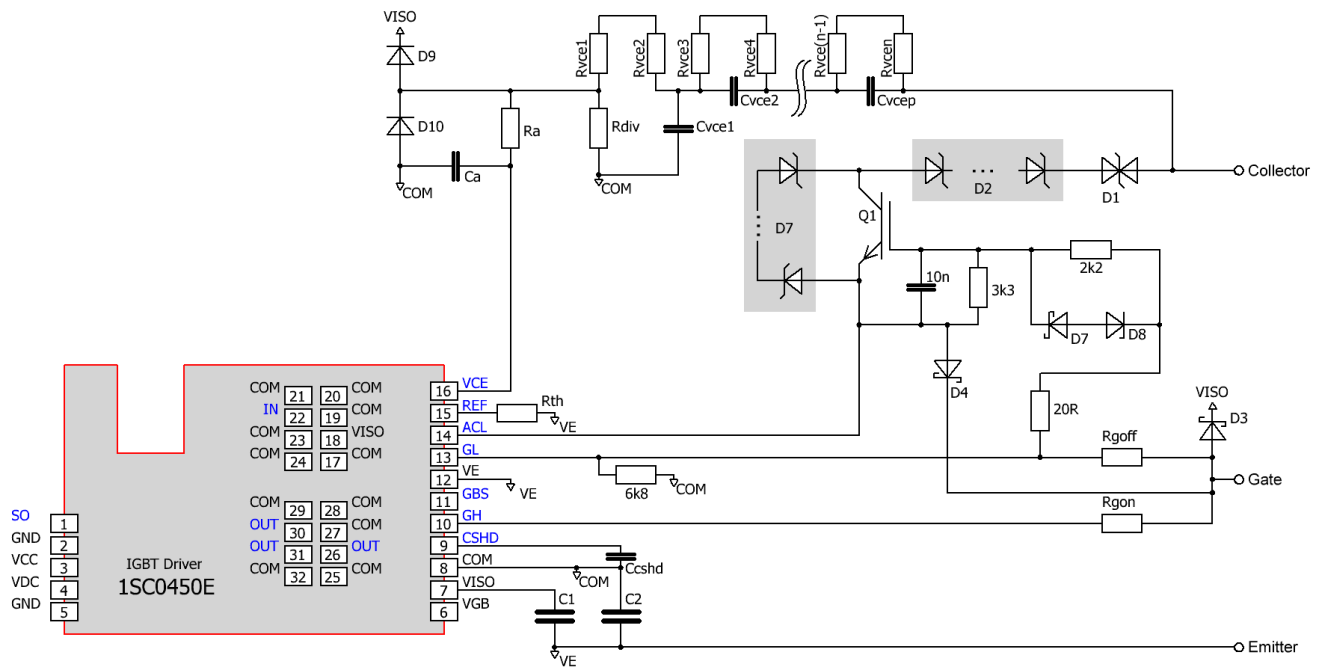

Fig. 6 Recommended user interface of the 1SC0450E2B0 (secondary-side pins 6 to 16) without gate boosting (refer to chapter "Gate Boosting" and Fig. 11 for gate-boosting circuitry)

Preliminary Description & Application Manual

Pins 17 to 32

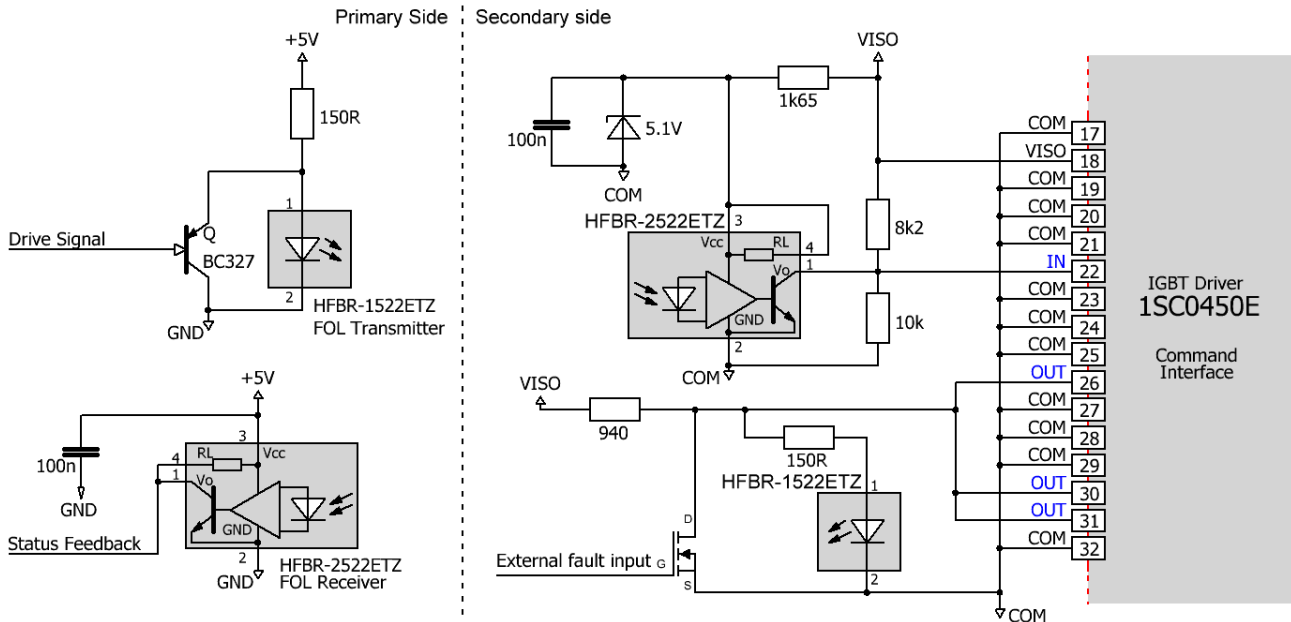

Fig. 7 Recommended command interface circuitry with Avago fiber-optic links HFBR-x522ETZ

Description of Secondary-Side Interfaces

General

The driver’s secondary side is equipped with an 11-pin and two 8-pin interface connectors.

The 11-pin interface connector features the following terminals:

- 1x DC/DC output terminal VISO
- 1x emitter terminal VE
- 1x secondary-side ground COM
- 1x collector sense terminal VCE
- 1x reference terminal REF for short-circuit protection
- 1x input terminal CSHD to set the turn-off delay after fault
- 1x active clamping terminal ACL
- 1x turn-on gate terminal GH
- 1x turn-off gate terminal GL
- 1x gate-boosting power supply VGB
- 1x gate-boosting signal GBS

The two 8-pin interface connectors combine the command interface and feature the following terminals:

- 1x DC/DC output terminal VISO
- 11x secondary-side ground COM
- 1x PWM input (inverted)
- 3x status feedback input/output (inverted)

All inputs and outputs are ESD-protected.

Preliminary Description & Application Manual

DC/DC output (VISO), emitter (VE) and COM terminals

The driver is equipped with blocking capacitors on the secondary side of the DC/DC converter (for values refer to the data sheet /3/). IGBTs with a gate charge of up to 4.7μC can be driven without additional external capacitors (C_1 and C_2 in Fig. 6 are not assembled). Eq. 1 and Eq. 2 give the recommended capacitance value of C_1 and C_2 for gate charges above this value:

$$C_1[\mu\text{F}] \geq (Q_G[\mu\text{C}] - 4.7) \cdot 4 \quad \begin{array}{l} C_1 \text{ in Fig. 6; } 4\mu\text{F blocking capacitance} \\ \text{per } 1\mu\text{C gate charge between VISO} \\ \text{and VE} \end{array} \quad \text{Eq. 1}$$

$$C_2 = \frac{C_1}{2} \quad \begin{array}{l} C_2 \text{ in in Fig. 6; blocking capacitance} \\ \text{between VE and COM, half of the } C_1 \\ \text{value} \end{array} \quad \text{Eq. 2}$$

Example: IGBT modules with a gate charge of up to 42μC can be driven with external capacitances of 149.2μF between the VISO and VE terminals and 74.6μF between the VE and COM terminals (C_1 and C_2 of Fig. 6).

If the capacitance C_1 (or C_2) exceeds 200μF (or 100μF), please contact the Power Integrations support service.

The blocking capacitors must be connected as close as possible to the driver's terminal pins with minimum inductance. Ceramic capacitors with a dielectric strength $\geq 25\text{V}$ are recommended.

No static load must be applied between VISO and VE, or between VE and COM. A static load can be applied between VISO and COM if necessary.

Reference terminal (REF)

The reference terminal REF allows the threshold to be set for short-circuit protection with a resistor placed between REF and VE (R_{th} of Fig. 6). An internal resistor of 68kΩ sets the default threshold value to 10.2V. It can be reduced with the use of an external resistor R_{th} according to the following Eq. 3:

$$R_{th}[\text{k}\Omega] = \frac{68 \cdot V_{th}[\text{V}]}{10.2 - V_{th}[\text{V}]} \quad \text{with } V_{th} < 10.2\text{V} \quad \text{Eq. 3}$$

It is recommended to keep the reference voltage at its maximum default value of 10.2V (without using an external resistor R_{th}).

Collector sense (VCE)

The collector sense must be connected to the IGBT collector with the circuit shown in Fig. 6 in order to detect a short circuit condition.

General information and recommendations:

- The overall value R_{tot} of the resistors R_{Vcei} is calculated with equation Eq. 4:

$$R_{tot} = \sum_{i=1}^n R_{Vcei} = R_{Vce1} + \dots + R_{Vcen} \quad \text{Eq. 4}$$

- It is recommended to dimension the overall value R_{tot} of the resistors in order for a current I_{Vce} of about 0.6...0.8mA to flow through them at the maximum DC-link voltage (Eq. 5). This current must not exceed 0.8mA. It is recommended to use series-connected resistors; the minimum creepage and clearance distances required for the application must be considered and the maximum voltage,

Preliminary Description & Application Manual

power and temperature rating of the resistors used must not be exceeded. Dimensioning recommendations are given below.

$$I_{Vce} \cong \frac{V_{DC-link(max)}}{R_{tot}} = 0.6...0.8mA \quad \text{Eq. 5}$$

- All resistors R_{Vcei} ($i \geq 1$) must have the same value.
- R_{div} allows the static threshold detection level V_{CEth} to be increased if required (resistive voltage divider with R_{tot}). R_{div} can be calculated with Eq. 6 in order to determine the static detection level V_{CEth} .

$$R_{div}[k\Omega] = R_{tot}[k\Omega] \cdot \frac{V_{th}[V] + |V_{GL}[V]|}{V_{CEth}[V] - V_{th}[V]} \quad (V_{CEth} > V_{th}) \quad \text{Eq. 6}$$

$|V_{GL}|$ is the absolute value of the gate-emitter turn-off voltage at the driver output. It depends on the driver load and can be found in the driver data sheet /3/. V_{th} is the reference value set at the reference terminal REF as described in the "Reference terminal (REF)" section.

- The recommended range for the overall capacitance value C_{tot} is given in Eq. 7:

$$C_{tot} = \frac{1}{\sum_{k=1}^p \frac{1}{C_{Vcek}}} = 1...4pF \quad \text{Eq. 7}$$

- All capacitances C_{Vcek} with $k \geq 2$ must have the same value.
- The capacitance C_{Vce1} must be chosen such that the Eq. 8 is satisfied:

$$\frac{C_{Vce1}}{C_{tot}} = (0.7...0.9) \cdot \frac{R_{tot}}{R_{Vce1} + R_{Vce2}} \quad \text{Eq. 8}$$

- The maximum voltage rating of the resistors and capacitors used must not be exceeded. Peak values and average values must be considered. Dimensioning recommendations are given below.
- The diodes D_9 and D_{10} must have a very low leakage current and a blocking voltage of $>40V$ (e.g. BAS416). Schottky diodes must be explicitly avoided.
- R_a and C_a are used to set the response time.

Recommended values for 6500V IGBTs with DC-link voltages up to 4500V

- $R_{Vce1} = R_{Vce2} = \dots = R_{Vce30} = 200k\Omega$ (500mW, 400V_{peak}, 1%)
- $R_{div} = 620k\Omega$ (0603, 1%)
- $C_{Vce1} = 15pF$ (C0G, 1000V, 5%)
- $C_{Vce2} = C_{Vce3} = \dots = C_{Vce15} = 22pF$ (C0G, 630V, 5%)
- $C_a = 22pF$ (C0G, 50V, 5%)
- $R_{th} = \text{not assembled}$
- $R_a = \text{refer to Table 1 below}$ (0603, 1%)

This setup uses 30 resistors R_{Vcei} and 15 capacitors C_{Vcek} and leads to a static desaturation detection threshold of about 201V.

Preliminary Description & Application Manual

$V_{DC-Link}$	$R_a=68k\Omega$	$R_a=91k\Omega$	$R_a=120k\Omega$
4500V	5.3 μ s	6.9 μ s	9.0 μ s
3000V	5.3 μ s	7.0 μ s	9.1 μ s
2250V	5.5 μ s	7.0 μ s	9.1 μ s
1500V	7.2 μ s	8.0 μ s	9.4 μ s
1125V	9.9 μ s	10.3 μ s	11.1 μ s
900V	14.1 μ s	14.1 μ s	14.2 μ s

Table 1 Typical response time as a function of the resistance R_a and the DC-link voltage $V_{DC-Link}$

Table 1 gives indicative values only. The response time depends on the specific layout and the IGBT module used. It is therefore recommended to measure the short-circuit duration in the final design.

Note that slow IGBT modules may report a wrong V_{CE} desaturation fault at turn-on. It is therefore recommended to test the setup under worst case conditions (maximum DC-link voltage, maximum collector current and highest IGBT junction temperature). Please also refer to AN-1101 /4/ for more information.

Recommended values for 4500V IGBTs with DC-link voltages up to 3200V

- $R_{vce1}=R_{vce2}=\dots=R_{vce20}=220k\Omega$ (500mW, 400V_{peak}, 1%)
- $R_{div}=620k\Omega$ (0603, 1%)
- $C_{vce1}=15pF$ (C0G, 1000V, 5%)
- $C_{vce2}=C_{vce3}=\dots=C_{vce10}=22pF$ (C0G, 630V, 5%)
- $C_a=22pF$ (C0G, 50V, 5%)
- R_{th} =not assembled
- R_a =refer to Table 2 below (0603, 1%)

This setup uses 20 resistors R_{vcei} and 10 capacitors C_{vcek} and leads to a static desaturation detection threshold of about 150V.

$V_{DC-Link}$	$R_a=68k\Omega$	$R_a=91k\Omega$	$R_a=120k\Omega$
3200V	5.1 μ s	6.8 μ s	8.8 μ s
2000V	5.2 μ s	6.8 μ s	8.9 μ s
1500V	6.1 μ s	7.0 μ s	8.9 μ s
1000V	8.8 μ s	9.3 μ s	10.3 μ s
800V	12.7 μ s	13.1 μ s	12.9 μ s

Table 2 Typical response time as a function of the resistance R_a and the DC-link voltage $V_{DC-Link}$

Table 2 gives indicative values only. The response time depends on the specific layout and the IGBT module used. It is therefore recommended to measure the short-circuit duration in the final design.

Note that slow IGBT modules may report a wrong V_{CE} desaturation fault at turn-on. It is therefore recommended to test the setup under worst case conditions (maximum DC-link voltage, maximum collector current and highest IGBT junction temperature). Please also refer to AN-1101 /4/ for more information.

Preliminary Description & Application Manual

Recommended values for 3300V IGBTs with DC-link voltages up to 2200V

- $R_{vce1}=R_{vce2}=\dots=R_{vce14}=220k\Omega$ (500mW, 400V_{peak}, 1%)
- $R_{div}=1.5M\Omega$ (0603, 1%)
- $C_{vce1}=15pF$ (C0G, 1000V, 5%)
- $C_{vce2}=C_{vce3}=\dots=C_{vce7}=22pF$ (C0G, 630V, 5%)
- $C_a=22pF$ (C0G, 50V, 5%)
- R_{th} =not assembled
- R_a =refer to Table 3 below (0603, 1%)

This setup uses 14 resistors R_{vcei} and 7 capacitors C_{vcek} per channel and leads to a static desaturation detection threshold of about 50V.

$V_{DC-Link}$	$R_a=68k\Omega$	$R_a=91k\Omega$	$R_a=120k\Omega$
2200V	5.3 μ s	7.0 μ s	9.0 μ s
1500V	5.3 μ s	7.0 μ s	9.0 μ s
1100V	5.4 μ s	7.0 μ s	9.1 μ s
700V	7.6 μ s	8.1 μ s	9.3 μ s
600V	17.0 μ s	14.4 μ s	13.7 μ s

Table 3 Typical response time as a function of the resistance R_a and the DC-link voltage $V_{DC-Link}$

Table 3 gives indicative values only. The response time depends on the specific layout and the IGBT module used. It is therefore recommended to measure the short-circuit duration in the final design.

Note that slow IGBT modules may report a wrong V_{CE} desaturation fault at turn-on. It is therefore recommended to test the setup under worst case conditions (maximum DC-link voltage, maximum collector current and highest IGBT junction temperature). Please also refer to AN-1101 /4/ for more information.

Input for adjusting the turn-off delay in fault condition (CSHD)

The terminal CSHD allows the delay in turning off the IGBT after a fault detection on the driver's secondary side (short-circuit, undervoltage, external fault input) to be determined with a capacitor C_{cshd} (C0G/50V) with a maximum value of 10nF connected to COM. Table 4 shows the resulting delay as a function of the circuit used at pin CSHD.

Circuit at pin CSHD	Typical turn-off delay T_{cshd}	
Left open:	$T_{cshd}=0.2\mu$ s	Eq. 9
Capacitor between CSHD and COM:	$T_{cshd}[\mu$ s] $=\frac{C_{cshd}[\text{pF}]}{50}$ ($C_{cshd}\leq 10\text{nF}$)	Eq. 10

Table 4 Turn-off delay as a function of CSHD wiring

As soon as the fault turn-off delay time T_{cshd} has elapsed, the driver's channel is automatically turned off.

The driver's channel can also be turned off from the driver's input IN within the turn-off delay time T_{cshd} determined by the CSHD pin after a secondary-side fault detection.

Note that it will not be possible to turn the IGBT on during about 100ns per 100pF capacitance applied to CSHD after a fault condition, starting from the turn-off event of the IGBT (minimum off-time required).

Preliminary Description & Application Manual

Active Clamping (ACL)

Active clamping is a technique designed to partially turn on the power semiconductor as soon as the collector-emitter voltage exceeds a predefined threshold. The power semiconductor is then kept in linear operation.

Basic active clamping topologies implement a single feedback path from the IGBT's collector through transient voltage suppressor devices (TVS) to the IGBT gate. The 1SC0450E2B0 supports Advanced Active Clamping from Power Integrations, where the feedback is also provided to the driver's secondary side at pin ACL (Fig. 6): as soon as the voltage at pin ACL exceeds about 1.3V, the turn-off MOSFET is progressively switched off in order to improve the effectiveness of the active clamping and to reduce the losses in the TVS. The turn-off MOSFET is turned completely off when the voltage at pin ACL approaches 20V (measured to COM).

It is recommended to use the circuit shown in Fig. 6. The following parameters must be adapted to the application:

- For TVS D_1 , D_2 it is recommended to use:
 - 3300V IGBTs with DC-link voltages up to 2200V: Seven unidirectional 300V TVS and one bidirectional 350V TVS. Good clamping results can be obtained with seven unidirectional TVS P6SMB300A and one bidirectional TVS P6SMB350CA from Diotec.
 - 4500V IGBTs with DC-link voltages up to 3200V: Eight unidirectional 400V TVS and one bidirectional 350V TVS. Good clamping results can be obtained with eight unidirectional TVS P6SMB400A and one bidirectional TVS P6SMB350CA from Diotec.
 - 6500V IGBTs with DC-link voltages up to 4350V: Ten unidirectional 440V TVS and one bidirectional 440V TVS. Good clamping results can be obtained with ten unidirectional TVS P6SMB440A and one bidirectional TVS P6SMB440CA from Diotec.

At least one bidirectional TVS (D_1) ($\geq 300V$ for 3300V IGBTs, $\geq 350V$ for 4500V IGBTs, $\geq 440V$ for 6500V IGBTs) must be used in order to avoid negative current flowing through the TVS chain during turn-on of the anti-parallel diode of the IGBT module due to its forward recovery behavior. Such a current could, depending on the application, lead to under-voltage of the driver secondary-side voltage VISO to VE (15V).

Note that it is possible to modify the number of TVS in a chain. The active clamping efficiency can be improved by increasing the number of TVS used in a chain if the total breakdown voltage remains at the same value. Note also that the active clamping efficiency is highly dependent on the type of TVS used (e.g. manufacturer).

- D_3 and D_4 : It is recommended to use Schottky diodes with blocking voltages $> 35V$ ($> 1A$ depending on the application).

Please note that the diodes D_3 and D_4 must not be omitted if Advanced Active Clamping is used.

If active clamping is not used, the diode D_4 can be omitted. The pin ACLx must then be left open.

Gate turn-on (GH) and turn-off (GL) terminals

These terminals allow the turn-on (GH) and turn-off (GL) gate resistors to be connected to the gate of the power semiconductor. The GH and GL pins are available as separated terminals in order to set the turn-on and turn-off resistors independently without the use of an additional diode. Please refer to the driver data sheet /3/ for the limit values of the gate resistors used.

A resistor between GL and COM of $6.8k\Omega$ (other values are also possible) may be used in order to provide a low-impedance path from the IGBT gate to the emitter even if the driver is not supplied with power. No static load (e.g. resistors) must be placed between GL and the emitter terminal VE.

Preliminary Description & Application Manual

Note, however, that it is not advisable to operate the power semiconductors within a half-bridge with a driver in the event of a low supply voltage. Otherwise, a steep increase of V_{CE} may cause partial turn-on of these IGBTs.

Gate Boosting Power Supply (VGB)

The driver supports an increased IGBT turn-on voltage source VGB to perform gate boosting. The voltage is generated by internal circuitry. No static load must be applied to VGB. Refer to the driver data sheet /3/ for more information.

Gate Boosting Signal (GBS)

The gate-boosting signal GBS is an auxiliary signal that has the same time waveform – but different voltage values – as the GH signal. Please refer to the driver data sheet for the exact voltage values /3/ and to the “Gate Boosting” section for more information.

Note that no static load must be applied to GBS. Refer to the driver data sheet /3/ for more information.

Gate Drive Input (IN)

The gate drive input signal IN is inverted to the gate output. A transition to a low-level state at IN generates a driver turn-on command while a transition to a high-level state generates a driver turn-off command. Also refer to Table 5 and Fig. 8.

It is recommended to use the input circuitry of Fig. 7. The drive signal is then not inverted to the gate output according to Table 5.

If other drive circuits are used, the following information must be considered:

- The absolute maximum ratings of the driver data sheet /3/ must be respected.
- The logic level thresholds of the input IN are given in the driver data sheet /3/.
- The input IN features an internal pull-up current source of about 500 μ A which sets its potential to a high-level state and assures an IGBT off-state condition if the pin is floating. Refer to the driver data sheet /3/ for values.
- Pin IN belongs to the secondary-side electrical circuit and follows the emitter potential of the driven IGBT. It must be isolated against primary-side circuits, e. g. with fiber-optic links.

Drive Signal	T/R ⁽¹⁾ Light	Input IN	Gate Output
Low	Off	High	Off-state
High	On	Low	On-state

Table 5 Signal input truth table correlated with the schematics of Fig. 7

Status Feedback / Fault input (OUT)

The OUT terminal is mainly used as a status feedback output. However, it also works as an input. When OUT is externally shorted to COM for a minimum period of time (timing and threshold values according to the driver data sheet /3/), the driver detects an external fault. The IGBT is then turned off after a delay

⁽¹⁾ T/R: Transmitter and receiver pair of a fiber-optic link

Preliminary Description & Application Manual

T_{CSHD} (refer to the chapter “Input for adjusting the turn-off delay in fault condition (CSHD)”). Note that failure to respect the minimum hold time may lead to incorrect driver behavior.

The recommended circuitry for using the OUT terminal as an external fault input is shown in Fig. 7 (transistor connected to “External fault input”). The external effective capacitance (components and board parasitic capacitances referred to VISO, VE and COM) must not exceed the value given in the driver data sheet /3/ to avoid unexpected driver fault triggering in normal operation.

In normal operation, each edge of the control signal IN is acknowledged by the driver with a short pulse (OUT is switched to low for a short period of time; refer to driver data sheet /3/ for details). As this can be observed by the host controller, this method allows simple and continuous monitoring of all drivers and fiber-optic links of the system (Fig. 8).

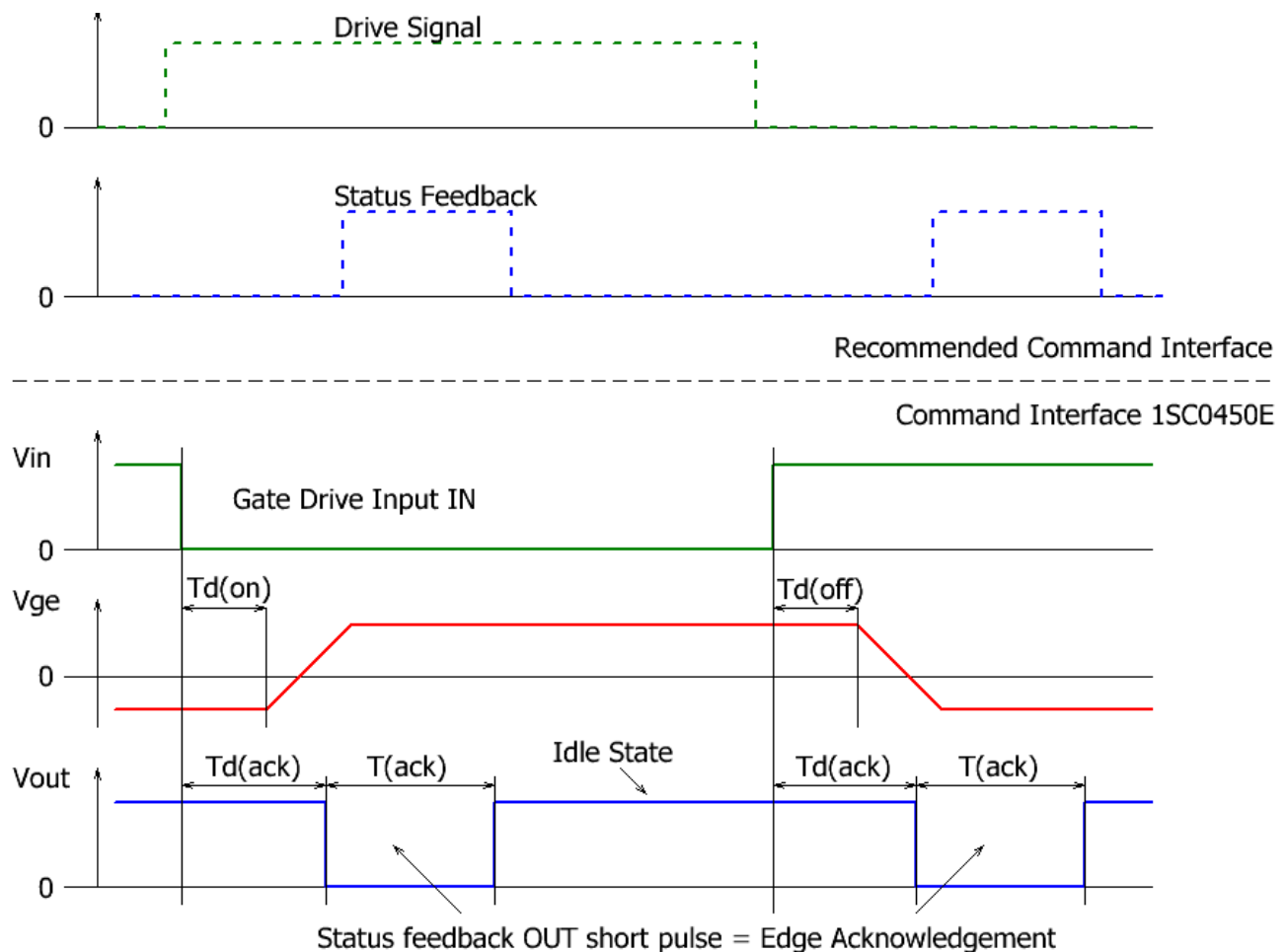

Fig. 8 Driver behavior and status feedback in normal operation (Refer to Fig. 7 for the recommended command interface)

The driver can detect three different secondary-side faults:

- V_{CE} -desaturation detection in case of a short-circuit; refer to chapter “Collector sense (VCE)”
- Secondary-side supply under-voltage; refer to chapter “Power-supply monitoring”
- External fault (as described above)

The signal truth table of Table 6 shows the behavior of the OUT signal in normal operation as well as in a fault condition. Only the pulse length of OUT differs between normal operation (acknowledge) and the different fault conditions.

Preliminary Description & Application Manual

Status	OUT	T/R ⁽²⁾ Light	Status Feedback
Idle	High	On	Low
Acknowledge or fault pulse	Low	Off	High

Table 6 Signal truth table correlated with the schematics of Fig. 7

Fig. 9 shows the response of the driver in the event of an IGBT short-circuit condition. The fault status is transferred to the status feedback terminal after the response time. The light is then driven “off” during the delay to clear the fault state ($8\mu\text{s} + T_{\text{cshd}}$). The driver turns the IGBT off after the response time + delay time T_{cshd} . The IGBT can be turned on again by applying a negative edge to the input IN after the fault status has disappeared.

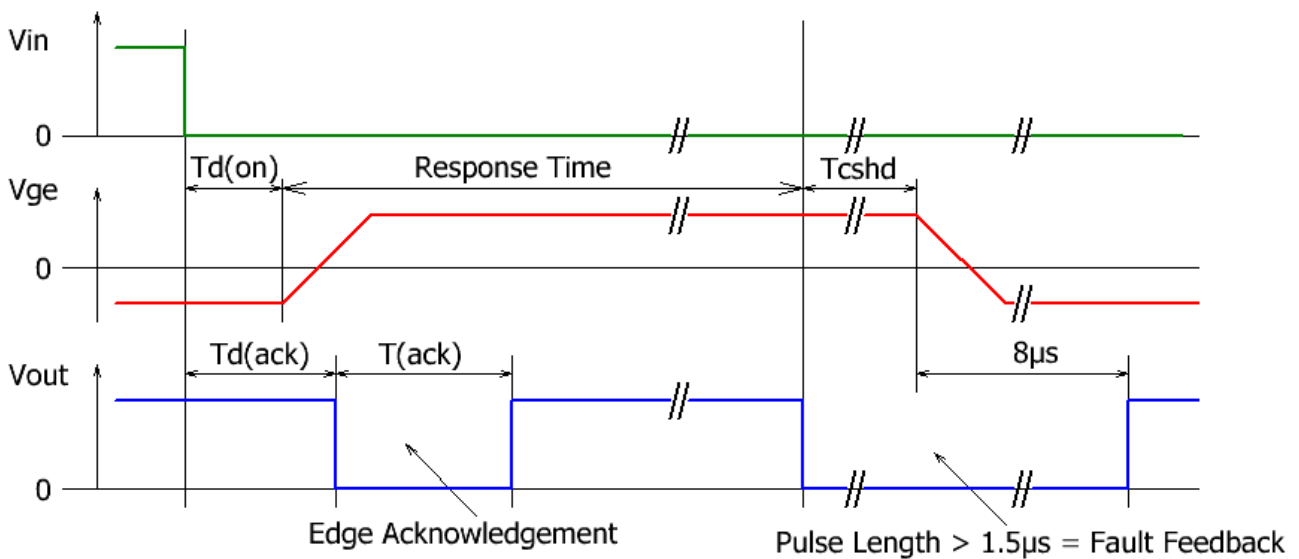

Fig. 9 Driver behavior and status feedback in the IGBT short-circuit condition

In case of a secondary-side supply under-voltage fault, the fault status remains active as long as this under-voltage remains. The driver response in the event of a supply under-voltage on VISO-VE is shown in Fig. 10.

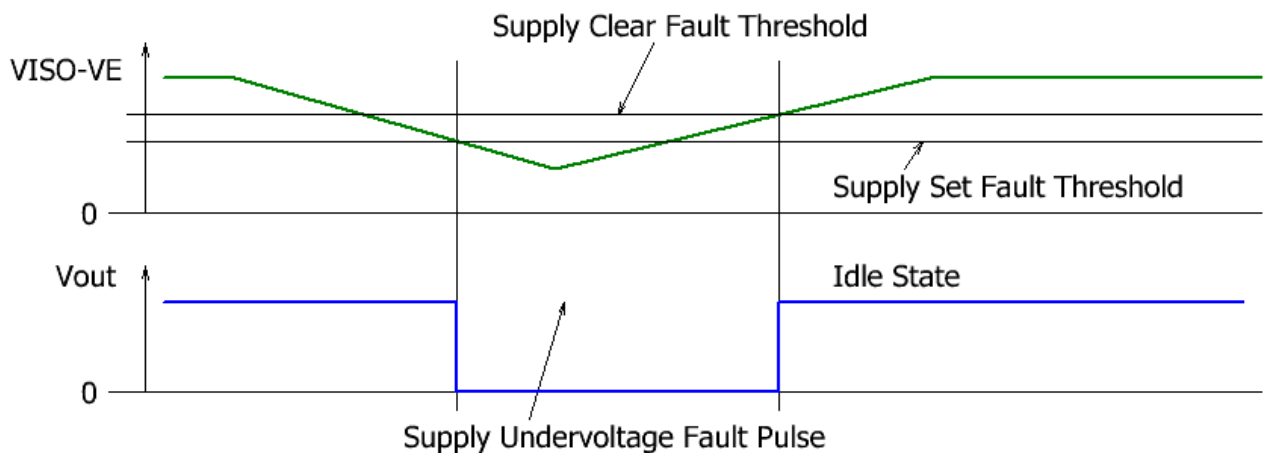

Fig. 10 Status feedback in the event of a secondary-side supply under-voltage

⁽²⁾ T/R: Transmitter and receiver pair of a fiber-optic link

Preliminary Description & Application Manual

During power-up, the status feedback will also show a fault condition until the supply under-voltage protection disappears.

If the OUT terminal is not used, it is recommended to connect the OUT pin to VISO via a pull-up resistor in the range of 1.5kΩ to 10kΩ.

How Do 1SC0450E2B0 SCALE-2 Drivers Work in Detail?

Power supply and electrical isolation

The driver is equipped with a DC/DC converter to provide an electrically insulated power supply to the gate driver circuitry. The transformer features basic insulation according to IEC 61800-5-1 as well as IEC 60664-1 between the primary and secondary sides.

Note that the driver requires a stabilized supply voltage.

Power-supply monitoring

The driver's primary and secondary sides are equipped with a local under-voltage monitoring circuit.

In the event of a primary-side supply under-voltage, the under-voltage is signaled by the electrical status output SO. A primary-side under-voltage will not automatically cause a gate turn-off command. This condition has to be detected by the control logic which has to switch off and block the gate drive signal.

In case of a secondary-side supply under-voltage, the corresponding power semiconductor is driven with a negative gate voltage after the delay in IGBT turn-off (refer to "Input for adjusting the turn-off delay in fault condition (CSHD)") to keep it in the off-state (the channel is blocked) and a fault condition is monitored on the status output OUT until the supply voltage exceeds the reference level for enabling.

Parallel connection of IGBT modules

It is recommended to drive parallel-connected IGBT modules using a single 1SC0450E2B0 driver core. Appropriate gate circuitry has to be used. Please contact the Power Integrations support service for more information.

3-level or multilevel topologies

In applications with multi-level topologies, the turn-off sequence of the individual power semiconductors usually needs to be controlled by the host controller in case of a detected fault condition (e.g. short circuit, over-current), especially if no Advanced Active Clamping or Dynamic Advanced Active Clamping is implemented.

In that case, the turn-off delay in the fault condition of the different drivers can be adjusted to match the corresponding timing specifications. It is in particular possible to determine a specific turn-off delay for the inner IGBTs of a 3-level NPC topology as described in the section: "Input for adjusting the turn-off delay in fault condition (CSHD)". The driver's response time can also be adapted accordingly if required.

Note however that Advanced Active Clamping offers simple and safe protection that allows excessive collector-emitter overvoltages to be avoided in case of wrong commutation sequences in the short-circuit condition of 3-level converter topologies (refer to /6/ and /7/ for more information).

Preliminary Description & Application Manual

Gate Boosting

The 1SC0450E2B0 driver supports gate boosting. This feature allows the commutation speed of the collector-emitter voltage to be accelerated at turn-on after the critical phase of the diode reverse recovery behavior to reduce the IGBT turn-on losses.

A dedicated external circuit as shown in Fig. 11 is required. Detailed gate-boosting recommendations are not currently available.

Gate-boosting circuit principle

The "Gate Boosting Logic" according to Fig. 11 has to trigger the boosting function at the appropriate time during the IGBT turn on transition as illustrated in Fig. 12:

- The delay time between GBS and the required boosting time needs to be determined by the "Gate Boosting Logic" circuit.
- The pulse length of the boosting pulse also needs to be determined by the "Gate Boosting Logic" circuit. It must be limited to a few microseconds.

A turn-on pulse of the gate-boosting power switch Q_1 will be generated. This will lead to an increased turn-on gate current that will be injected into the IGBT gate over R_{gb} .

The boosting charge capability can be increased by adding an external capacitor C_{gb} . The minimum value C_{gb} of the external capacitor can be calculated according to Eq. 11.

$$C_{gb}[\text{nF}] = \frac{Q_{gb}[\text{nC}]}{V_{GH}[\text{V}] + |V_{GL}[\text{V}]|} - 22 \quad C_{gb} \geq 0 \quad \text{Eq. 11}$$

where Q_{gb} stands for the required boosting gate charge and has to be determined according to the IGBT module gate charge requirements. V_{GH} and V_{GL} are the absolute values of the turn-on and turn-off voltage at the driver output respectively. Their value can be found in the driver data sheet /3/. Note that Eq. 11 assumes a full discharge of C_{gb} during a gate-boosting event (worst case).

The gate-boosting capability is further limited by the minimum time span between two consecutive gate turn-on commands as well as by the gate-boosting power. The minimum required time T_{min} between two consecutive gate turn-on commands is given by Eq. 12. The gate-boosting efficiency is reduced if Eq. 12 is not respected.

$$T_{min}[\mu\text{s}] = 11 \cdot \left(1 + \frac{22 + C_{gb}[\text{nF}]}{22} \right) + T_{gb}[\mu\text{s}] \quad \text{Eq. 12}$$

T_{gb} stands for the gate-boosting pulse length (Fig. 12). It is recommended to limit it to 1...5 μs .

The maximum gate-boosting power must be within the absolute maximum ratings of the driver data sheet /3/. Eq. 13 gives a worst case approximation of the real gate-boosting power P_{gb} . It is sufficient to design the gate boosting such that P_{gb} is lower than the corresponding absolute maximum rating of the driver data sheet /3/.

$$P_{gb}[\text{W}] = 10^{-6} \cdot (C_{gb}[\text{nF}] + 22 + 6.5 \cdot T_{gb}[\mu\text{s}]) \cdot (V_{GH}[\text{V}] + |V_{GL}[\text{V}]|)^2 \cdot f[\text{kHz}] \quad \text{Eq. 13}$$

Preliminary Description & Application Manual

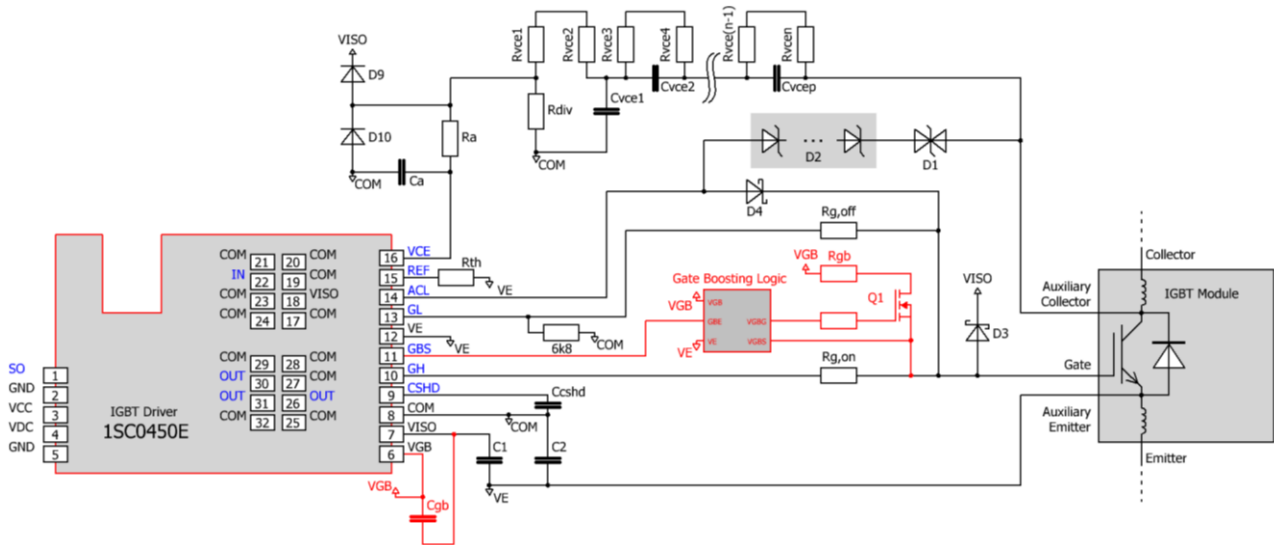

Fig. 11 Gate-boasting circuit principle – highlighted in red color

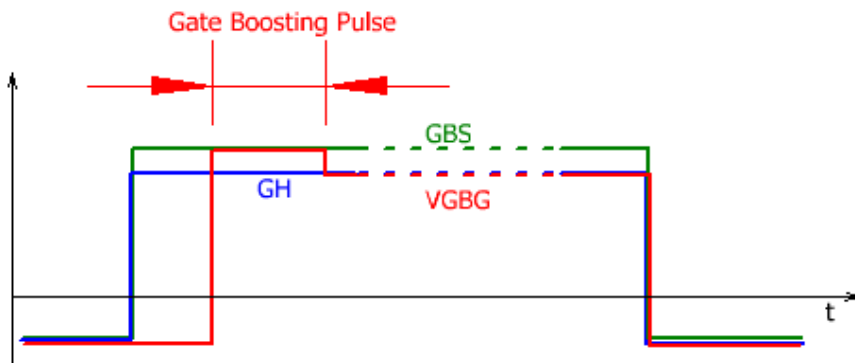

Fig. 12 Gate-boasting signals

How to disable gate boosting?

Pins VGB and GBS must be left open. Note that the voltage values of the pins VGB and GBS are 50V and 35V respectively referred to COM (creepage and clearance distances).

Preliminary Description & Application Manual

Bibliography

- /1/ Paper: Smart Power Chip Tuning, Bodo's Power Systems, May 2007
- /2/ "Description and Application Manual for SCALE™ Drivers", Power Integrations
- /3/ Data sheet SCALE™-2 driver core 1SC0450E2B0, Power Integrations
- /4/ Application note AN-1101: Application with SCALE™-2 and SCALE™-2+ Gate Driver Cores, Power Integrations
- /5/ Application note AN-0904: Direct Paralleling of SCALE™-2 Gate Driver Cores, Power Integrations
- /6/ Application note AN-0901: Methodology for Controlling Multi-Level Converter Topologies with SCALE™-2 IGBT Drivers, Power Integrations
- /7/ Paper: Safe Driving of Multi-Level Converters Using Sophisticated Gate Driver Technology, PCIM Asia, June 2013

Note: The Application Notes are available on the Internet at www.power.com/igbt-driver/go/app-note and the papers at www.power.com/igbt-driver/go/papers.

Preliminary Description & Application Manual

The Information Source: SCALE-2 Driver Data Sheets

Power Integrations offers the widest selection of gate drivers for power MOSFETs and IGBTs for almost any application requirements. The largest website on gate-drive circuitry anywhere contains all data sheets, application notes and manuals, technical information and support sections: www.power.com.

Quite Special: Customized SCALE-2 Drivers

If you need an IGBT driver that is not included in the delivery range, please don't hesitate to contact Power Integrations or your Power Integrations sales partners.

Power Integrations has more than 25 years of experience in the development and manufacturing of intelligent gate drivers for power MOSFETs and IGBTs and has already implemented a huge number of customized solutions.

Technical Support

Power Integrations provides expert help for your questions and problems:

www.power.com/igbt-driver/go/support

Quality

The obligation to high quality is one of the central features laid down in the mission statement of Power Integrations Switzerland GmbH. Our total quality management system assures state-of-the-art processes throughout all functions of the company, certified by ISO9001:2008 standards.

Legal Disclaimer

The statements, technical information and recommendations contained herein are believed to be accurate as of the date hereof. All parameters, numbers, values and other technical data included in the technical information were calculated and determined to our best knowledge in accordance with the relevant technical norms (if any). They may base on assumptions or operational conditions that do not necessarily apply in general. We exclude any representation or warranty, express or implied, in relation to the accuracy or completeness of the statements, technical information and recommendations contained herein. No responsibility is accepted for the accuracy or sufficiency of any of the statements, technical information, recommendations or opinions communicated and any liability for any direct, indirect or consequential loss or damage suffered by any person arising therefrom is expressly disclaimed.

Preliminary Description & Application Manual

Ordering Information

Our international terms and conditions of sale apply.

Type Designation	Description
------------------	-------------

1SC0450E2B0-45	Single-channel SCALE-2 driver core for 4500V IGBTs
1SC0450E2B0-65	Single-channel SCALE-2 driver core for 6500V IGBTs

Product home page: www.power.com/igbt-driver/go/1SC0450

Refer to www.power.com/igbt-driver/go/nomenclature for information on driver nomenclature.

Information about Other Products

For other driver cores:

Direct link: www.power.com/igbt-driver/go/cores

For other drivers, product documentation and application support:

Please click: www.power.com

Preliminary Description & Application Manual

Power Integrations Sales Offices

WORLD HEADQUARTERS

5245 Hellyer Avenue
San Jose, CA 95138 USA
Tel: +1-408-414-9200
Fax: +1-408-414-9765
Email: usasales@power.com

AMERICAS WEST

5245 Hellyer Avenue
San Jose, CA 95138 USA
Tel: +1-408-414-8778
Fax: +1-408-414-3760
Email: usasales@power.com

GERMANY (AC-DC/LED Sales)

Lindwurmstrasse 114
80337 München, Germany
Tel: +49-89-5527-39100
Fax: +49-89-1228-5374
Email: eurosales@power.com

INDIA (Mumbai)

Unit: 106-107, Sagar Tech Plaza-B
Sakinaka, Andheri Kurla Road
Mumbai, Maharashtra 400072 India
Tel 1: +91-22-4003-3700
Tel 2: +91-22-4003-3600
Email: indiasales@power.com

JAPAN

Kosei Dai-3 Bldg.
2-12-11, Shin-Yokohama, Kohoku-ku
Yokohama-shi, Kanagawa
Japan 222-0033
Tel: +81-45-471-1021
Fax: +81-45-471-3717
Email: japansales@power.com

TAIWAN

5F, No. 318, Nei Hu Rd., Sec. 1
Nei Hu Dist.
Taipei, 114 Taiwan
Tel: +886-2-2659-4570
Fax: +886-2-2659-4550
Email: taiwansales@power.com

AMERICAS EAST

7360 McGinnis Ferry Road
Suite 225
Suwannee, GA 30024 USA
Tel: +1-678-957-0724
Fax: +1-678-957-0784
Email: usasales@power.com

CHINA (Shanghai)

Room 2410, Charity Plaza
No. 88 North Caoxi Road
Shanghai, 200030 China
Tel: +86-21-6354-6323
Fax: +86-21-6354-6325
Email: chinasales@power.com

GERMANY (IGBT Driver Sales)

HellwegForum 1
59469 Ense, Germany
Tel: +49-2938-64-39990
Email: igbt-driver.sales@power.com

INDIA (New Dehli)

#45, Top Floor
Okhla Industrial Area, Phase - III
New Dehli, 110020 India
Tel 1: +91-11-4055-2351
Tel 2: +91-11-4055-2353
Email: indiasales@power.com

KOREA

RM602, 6FL, 22
Teheran-ro 87-gil, Gangnam-gu
Seoul, 06164 Korea
Tel: +82-2-2016-6610
Fax: +82-2-2016-6630
Email: koreasales@power.com

UNITED KINGDOM

Bulding 5, Suite 21
The Westbrook Centre
Milton Road
Cambridge, CB4 1YG United Kingdom
Tel: +44-7823-557-484
Email: eurosales@power.com

AMERICAS CENTRAL

333 Sheridan Road
Winnetka, IL 60093 USA
Tel: +1-847-721-6293
Email: usasales@power.com

CHINA (Shenzhen)

17/F, Hivac Building, No 2
Keji South 8th Road, Nanshan District
Shenzhen, 518057 China
Tel: +86-755-8672-8689
Fax: +86-755-8672-8690
Email: chinasales@power.com

INDIA (Bangalore)

#1, 14th Main Road
Vasanthangar
Bangalore, 560052 India
Tel 1: +91-80-4113-8020
Tel 2: +91-80-4113-8028
Fax: +91-80-4113-8023
Email: indiasales@power.com

ITALY

Via Milanese 20
20099 Sesto San Giovanni (MI), Italy
Tel: +39-02-4550-8708
Email: eurosales@power.com

SINGAPORE

51 Newton Road
#19-01/05 Goldhill Plaza
Singapore, 308900
Tel 1: +65-6358-2160
Tel 2: +65-6358-4480
Fax: +65-6358-2015
Email: singaporesales@power.com