



Design Example Report

Title	<i>High Efficiency 18 W Power Supply Using TOPSwitch[®]-JX TOP264VG</i>
Specification	90 VAC – 265 VAC Input; 12 V, 1.5 A Output
Application	Adapter
Author	Applications Engineering Department
Document Number	DER-237
Date	March 19, 2015
Revision	1.5

Summary and Features

- Low component count
- Small PCB size of 35 mm x 50 mm
- 132 kHz switching frequency reduces size of magnetics
- Very low no-load input power (<80 mW at 230 VAC)
- High active mode efficiency at 115 VAC / 60 Hz (>85%)
 - Exceeds Energy Star 2.0 Efficiency Requirements: >84% at 115 V / 60 Hz, and 230 V / 50 Hz, with very high efficiency in both standby and sleep modes
 - Exceeds USA Energy Independence and Security Act 2007 of 76%
 - Exceeds EU CoC v4 and EuP Tier 2 requirement of 80%
- Excellent transient load response
- Hysteretic thermal overload and over-voltage protection with automatic recovery
- Meets limited power source requirements (<100 VA) with single point failure
- Power Integrations eDIP low-profile package
- No potting required to meet thermal specifications
- Meets Conducted EMI with > -6dB QP margin

PATENT INFORMATION

The products and applications illustrated herein (including transformer construction and circuits external to the products) may be covered by one or more U.S. and foreign patents, or potentially by pending U.S. and foreign patent applications assigned to Power Integrations. A complete list of Power Integrations' patents may be found at www.powerint.com. Power Integrations grants its customers a license under certain patent rights as set forth at <http://www.powerint.com/ip.htm>.

Power Integrations

5245 Hellyer Avenue, San Jose, CA 95138 USA.

Tel: +1 408 414 9200 Fax: +1 408 414 9201

www.powerint.com

Table of Contents

1	Introduction.....	4
2	Power Supply Specification	6
3	Schematic.....	7
4	Circuit Description	8
4.1	Input EMI Filtering	8
4.2	TOPSwitch-JX Primary.....	8
4.3	Energy Efficiency.....	9
4.4	Output Overvoltage Protection	9
4.5	Output Power Limiting	9
4.6	Output Rectification and Filtering	9
4.7	Thermal Overload Protection.....	9
5	PCB Layout	10
6	Bill of Materials	11
7	Transformer Specification.....	12
7.1	Electrical Diagram	12
7.2	Electrical Specifications.....	12
7.3	Materials.....	12
7.4	Transformer Build Diagram	13
7.5	Transformer Construction.....	14
8	Common Mode Coke Specification (L1)	15
8.1	Electrical Specifications.....	15
8.2	Materials.....	15
8.3	Winding instructions	15
8.4	Illustrations	15
9	Transformer Design Spreadsheet.....	16
10	Mechanical Drawings.....	20
10.1	TOP264VG (U1) Heatsink	20
10.2	Output Diode (D8) Heatsink	21
11	Performance Data	22
11.1	Full Load Efficiency	22
11.2	Active Mode Efficiency	23
11.3	Energy Efficiency Requirements	24
11.3.1	USA Energy Independence and Security Act 2007.....	25
11.3.2	ENERGY STAR EPS Version 2.0	25
11.4	No-load Input Power.....	26
11.5	Available Standby Output Power	27
11.6	Regulation	28
11.6.1	Load	28
11.6.2	Line	29
12	Thermal Performance	30
13	Waveforms.....	32
13.1	Drain Voltage and Current, Normal Operation.....	32
13.2	Output Voltage Start-up Profile.....	32
13.3	Drain Voltage and Current Start-up Profile	33



- 13.4 Output Diode Peak Inverse Voltage.....33
- 13.5 Load Transient Response (75% to 100% Load Step).....34
- 13.6 Output Ripple Measurements35
 - 13.6.1 Ripple Measurement Technique.....35
 - 13.6.2 Measurement Results.....36
- 13.7 Over-voltage Protection37
- 13.8 Limited Power Source (Over Power Protection)37
- 13.9 Control Loop Measurements38
- 13.10 115 VAC Maximum Load38
- 13.11 230 VAC Maximum Load39
- 14 Conducted EMI40
- 15 Revision History44

Important Note:

Although this board is designed to satisfy safety isolation requirements, the engineering prototype has not been agency approved. Therefore, all testing should be performed using an isolation transformer to provide the AC input to the prototype board.



1 Introduction

This document is an engineering report describing an adapter power supply utilizing a TOPSwitch-JX TOP264VG. This power supply is intended as a general purpose evaluation platform for adapter application that operates from universal input and provides a 12 V, continuous 18 W output. PCB board dimension is 35 mm x 50 mm.

The TOPSwitch-JX, by design, maintains virtually constant efficiency across a very wide load range without using special operating modes to meet specific load thresholds. This optimizes performance for existing and emerging energy-efficiency regulations. Maintaining constant efficiency ensures design optimization for future energy-efficiency regulation changes without the need for redesign.

The low MOSFET capacitance of TOPSwitch-JX allows a higher switching frequency without the efficiency penalty which occurs with standard discrete MOSFET. The 132 kHz switching frequency (rather than the 40 kHz to 60 kHz frequency used for a discrete MOSFET) reduces the transformer size required, and so reduces cost.

The power supply meets Energy Star 2.0 >79% average-efficiency, no-load <80 mW at 230 VAC and meets CISPR conducted EMI with more than 6dB margin.

This power supply offers thermal overload protection with auto-recovery using large hysteresis. It is primary-side sensed output overload and overvoltage protection, even with a single fault.

This document provides complete design details including specifications, the schematic, bill of materials, PCB layout and transformer design and construction information. This information includes performance results pertaining to regulation, efficiency, standby, transient load, power-limit data, and conducted EMI scans.



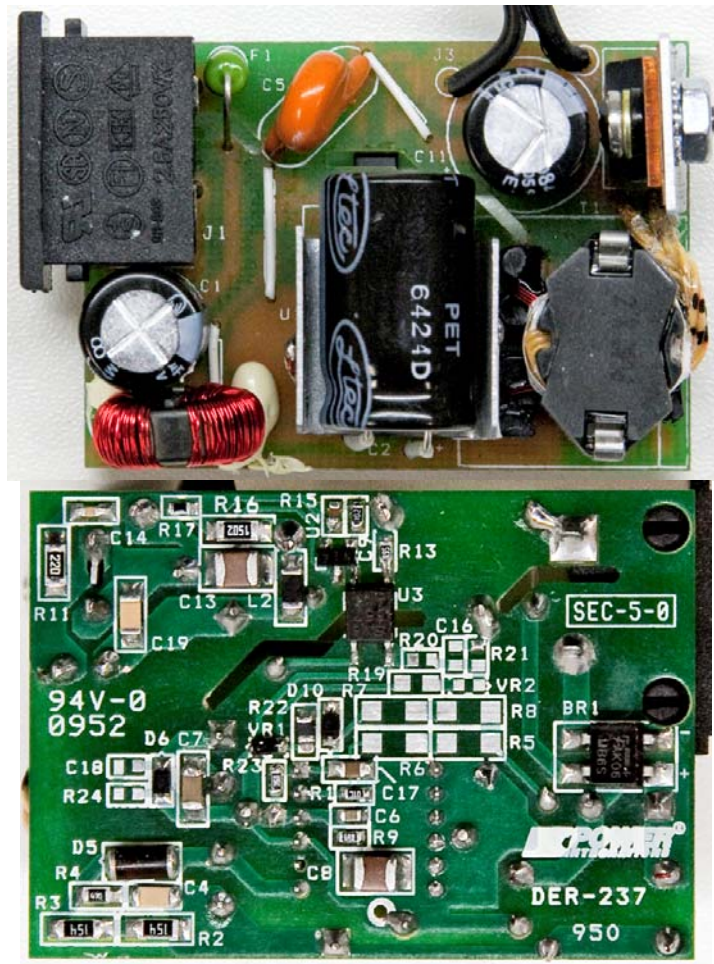

Figure 1 – Populated Circuit Board Photograph.

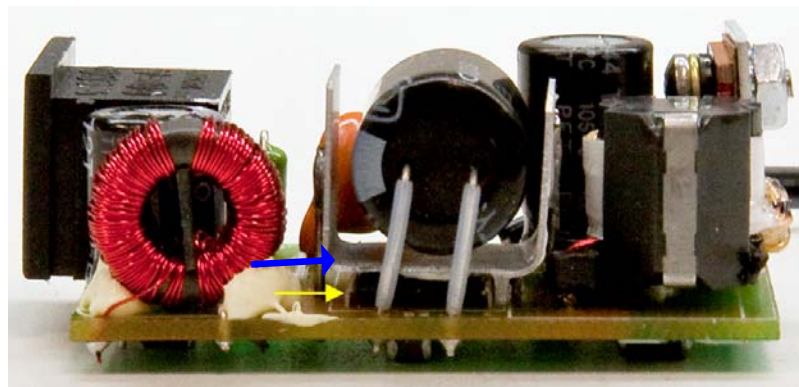

Figure 2 – Side View Showing TOP264VG V-Package with Heatsink Mounted on Top.



2 Power Supply Specification

The table below represents the minimum acceptable performance of the design. Actual performance is listed in the results section.

Description	Symbol	Min	Typ	Max	Units	Comment
Input						
Voltage	V_{IN}	90		265	VAC	2 Wire – no P.E.
Frequency	f_{LINE}	47	50/60	64	Hz	
No-load Input Power (230 VAC)				0,080	W	
Output						
Output Voltage 1	V_{OUT1}	11.4	12	12.6	V	± 5%, end of 1.8 m #22 AWG cable 20 MHz bandwidth
Output Ripple Voltage 1	$V_{RIPPLE1}$			330	mV _{PP}	
Output Current 1	I_{OUT1}	0		1.5	A	
Total Output Power						
Continuous Output Power	P_{OUT}			18	W	
Efficiency						
Full Load	η	83			%	Measured at P_{OUT} 25 °C
Required average efficiency at 25, 50, 75 and 100 % of P_{OUT}	$\eta_{ES2.0}$	79			%	Per ENERGY STAR V2.0
Environmental						
Conducted EMI		Meets CISPR22B / EN55022B				
Safety		Designed to meet IEC950 / UL1950 Class II				
Ambient Temperature	T_{AMB}	0	25	40	°C	Free convection, sea level



3 Schematic

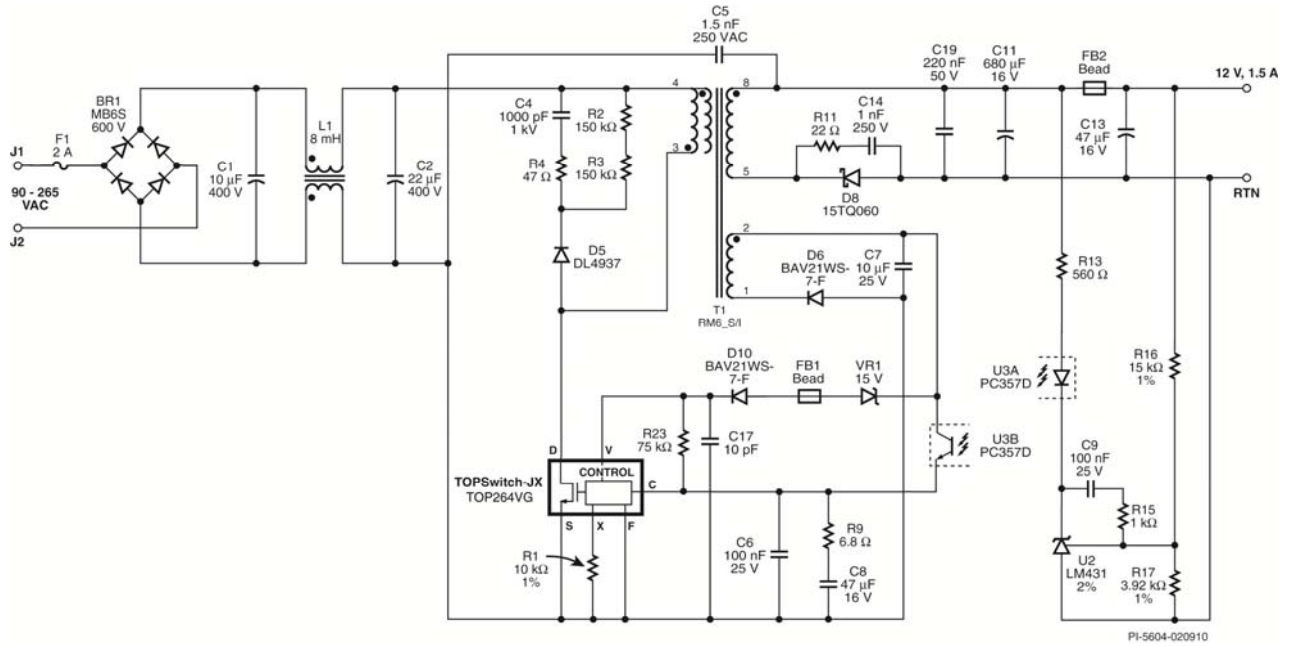

Figure 3 – Schematic.

4 Circuit Description

This power supply employs a TOP264VG integrated off-line switcher IC, (U1), in a flyback topology for low no-load, high efficiency and compact power supply operating from universal inputs and providing a 12 V, 18 W output. IC U1 has an integrated 725 V MOSFET and a multi-mode controller. It regulates the output by adjusting the MOSFET duty cycle, based on the current fed into its CONTROL (C) pin.

4.1 Input EMI Filtering

Fuse F1 provides catastrophic fault protection to the circuit, and isolates it from the AC source. Diode BR1 rectifies the AC input. Capacitor C1 and C2 filters the resulting DC. Bulk cap C1 reduces differential-mode noise EMI. Inductor L1 filters common-mode EMI. This input filter is compliant to UL standard 60950-1 without bleed resistor to allow safe removal of the AC source.

4.2 TOPSwitch-JX Primary

The EcoSmart[®] feature of U1 automatically provides constant efficiency over the entire load range. It uses a proprietary Multi-cycle-modulation (MCM) function to eliminate the need for special operating modes triggered at specific loads. This simplifies circuit design since it removes the need to design for aberrant or specific operating conditions or load thresholds.

A switching frequency of 132 kHz was chosen (vs. 66 kHz) to minimize transformer size. This high frequency operation has no major impact on efficiency or EMI thanks to very low capacitance PI MOSFET technology and proprietary frequency jitter feature

The TOP264VG regulates the output by adjusting the duty cycle based on the current into its CONTROL (C) pin. The power supply output voltage is sensed on the secondary side by shunt regulator U2 and provides a feedback signal to the primary side through optocoupler U3.

Capacitor C8 provides the auto-restart timing for U1, start-up and loop compensation. At startup this capacitor is charged through the DRAIN (D) pin. Once it is charged U1 begins to switch. Capacitor C8 stores enough energy to ensure the power supply output reaches regulation. After start-up, the bias winding powers the controller via the current through the optocoupler into the CONTROL pin. Bypass capacitor C6 is placed as physically close as possible to U1. Resistor R9 provides additional compensation to the feedback loop.

The clamp network formed by C4, R2, R3, R4, and D5 limits the drain voltage (preventing spikes at MOSFET turn off) and dissipates transformer leakage inductance energy.

To further improve the no load input power at high input voltage resistor R23 was added to provide a current of 25uA into the V pin from the C pin. This changes the operating point of the CONTROL pin (line feed forward function). With R23 fitted, the absolute



current into the CONTROL pin to set a given duty cycle is reduced by ~50% reducing power consumption from both the bias winding and output.

4.3 Energy Efficiency

The EcoSmart[®] feature of U1 provides constant efficiency over the entire load range. The proprietary Multi-mode control automatically achieves this performance, eliminating special operating modes triggered at specific loads, which greatly simplifies circuit design.

4.4 Output Overvoltage Protection

Open-loop faults cause the output voltage to exceed the specified maximum value. To prevent excessive output voltage levels in such cases, U1 utilizes an output overvoltage shutdown function. An increase in output voltage causes an increase in the bias winding on the primary side, sensed by VR1. A sufficient rise in the bias voltage causes VR1 to conduct and inject current into the Voltage (V) pin of U1. When the current exceeds 336 μ A for more than 100 μ s, U1 enters a latching overvoltage shutdown mode. Ferrite bead FB1 and C17 serve as filter for high frequency noise.

4.5 Output Power Limiting

X pin resistor R1 was set to reduce the internal current limit of U1. This allows the supply to limit the output power to <100 VA at high line and deliver the rated output at low line.

4.6 Output Rectification and Filtering

Schottky diode D8 rectifies the output. A snubber network (C14, R11) dampens ringing across the diodes and reduces high frequency conducted and radiated noise. These two components were chosen with smaller values to allow high-frequency ringing to be damped while keeping any power dissipation they cause at no-load to a minimum. Ferrite bead FB2 and capacitor C13 form an output second stage filter. Capacitors C11 and C19 provide output filtering. Resistors R16 and R17 form a voltage divider and set the DC set point of the output. Capacitor C9 and R15 provide compensation for the feedback control loop. Resistor R13 limits the gain of the feedback system to ensure power supply stability throughout the range of operation.

4.7 Thermal Overload Protection

IC U1 has an integrated, 100% tested, accurate latching thermal-overload protection feature. If the junction temperature reaches +142 °C (during a fault condition), U1 shuts down. The latch condition resets once the input voltage has been removed and C1 and C2 discharge.



5 PCB Layout

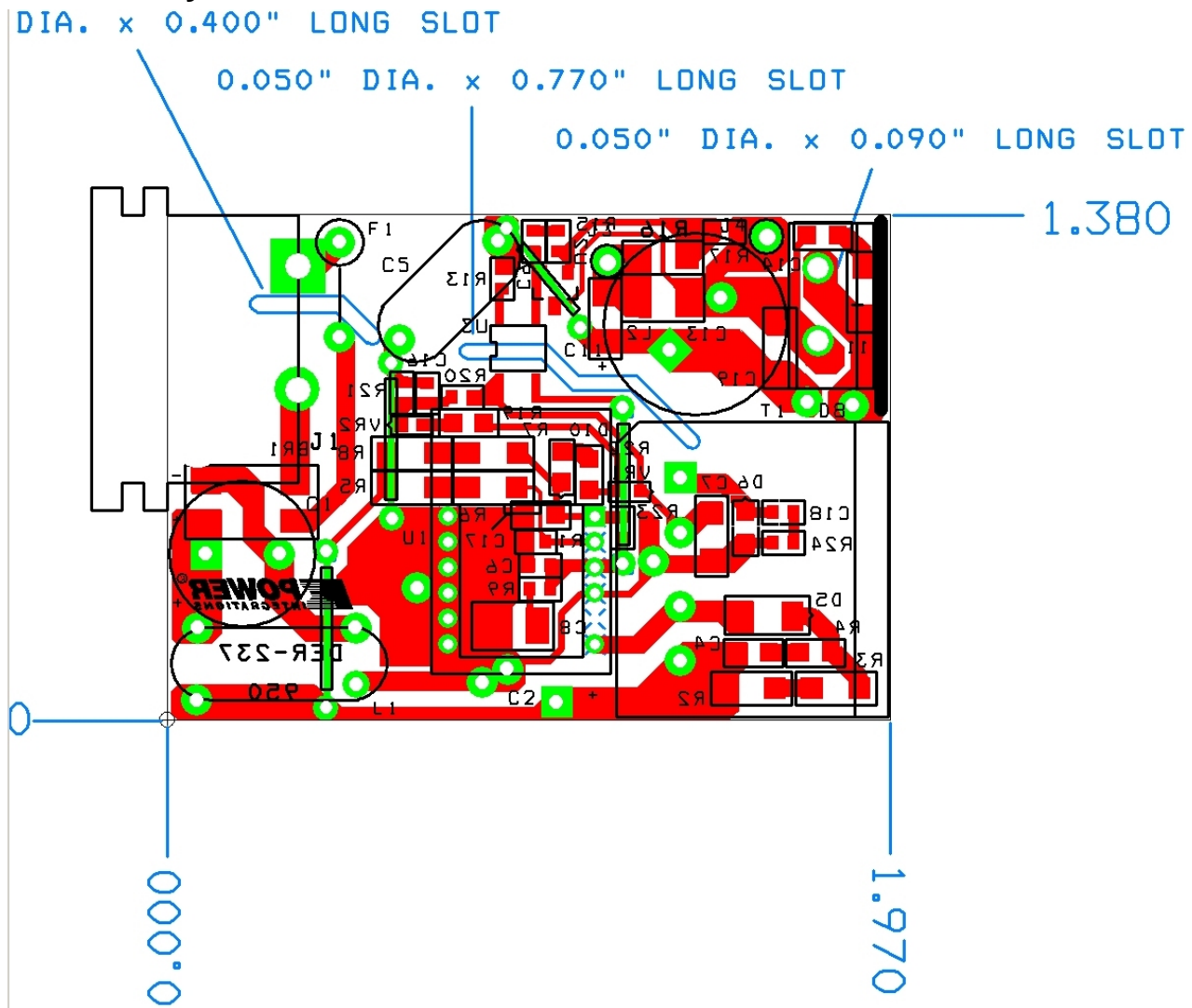

Figure 4 – Printed Circuit Layout (35 mm x 50 mm).

Note: Locations R5, R6, R7, R8, R19, R20, R21, C16, VR5, R24, & C18 are not populated.

6 Bill of Materials

Item	Qty	Ref Des	Description	Manuf. Part Number	Manufacturer
1	1	BR1	600 V, 0.5 A, Bridge Rectifier, SMD, DFS, SOIC-4	MB6S	Fairchild
2	1	C1	10 μ F, 400 V, Electrolytic, Low ESR, 79 mA, (10 x 12.5)	TYD2GM100G130	Ltec
3	1	C2	22 μ F, 400 V, Electrolytic, High Ripple, (12.5 x 18)	Not Provided	Samxon
4	1	C4	1000 pF, 50 V, Ceramic, X7R, 1206	ECJ-3FB2J102K	Panasonic
5	1	C5	1.5 nF, Ceramic, Y1	440LD15-R	Vishay
6	1	C6	100 nF 100 V, Ceramic, X7R, 0603	GRM188R72A104KA35D	Murata
7	1	C7	10 μ F, 25 V, Ceramic, X7R, 1206	ECJ-3YB1E106M	Panasonic
8	2	C8 C13	47 μ F, 16 V, Ceramic, X5R, 1210	GRM32ER61C476ME15L	Murata
9	1	C9	100 nF 25 V, Ceramic, X7R, 0603	ECJ-1VB1E104K	Panasonic
10	1	C11	680 μ F, 16 V, Electrolytic, Very Low ESR, 38 m Ω , (10 x 16)	EKZE160ELL681MJ16S	Nippon Chemi-Con
11	1	C14	470 pF, 250 V, Ceramic, X7R, 0805	GRM21AR72E473KW01D	Murata
12	1	C17	10 pF, 50 V, Ceramic, NPO, 0805	ECJ-2VC1H100D	Panasonic
13	1	C19	220 nF, 50 V, Ceramic, X7R, 1206	ECJ-3YB1H224K	Panasonic
14	1	D5	600 V, 1 A, Rectifier, Fast Recovery, MELF (DL-41)	DL4937-13-F	Diodes Inc
15	2	D6 D10	250 V, 0.2 A, Fast Switching, 50 ns, SOD-323	BAV21WS-7-F	Diode Inc.
16	1	D8	60 V, 15 A, Schottky, TO-220AC	15TQ060	International Rectifier
17	1	F1	2 A, 250 V, Slow, 5 mm x 20 mm, Axial	230002	Littelfuse
18	1	FB1 (R22)	Ferrite Bead, 8 Ω , 0805 SMD	FBMJ2125HL8R0NT	Taiyo Yuden
19	1	J1	AC Input Receptacle	S-01-02A	Sunfair
20	2	J3 J4	PCB Terminal Hole, 18 AWG	N/A	N/A
21	1	L1	8 mH, Common Mode Choke	FT-50-43	AMIDON
22	1	L2	Ferrite Bead, 68 Ω , 3A, 1206 SMD	EXC-ML32A680U	Panasonic
23	1	R1	10 k Ω , 1%, 1/16 W, Metal Film, 0603	ERJ-3EKF1002V	Panasonic
24	2	R2 R3	150 k Ω , 5%, 1/4 W, Metal Film, 1206	ERJ-8GEYJ154V	Panasonic
25	1	R4	47 Ω , 5%, 1/8 W, Metal Film, 0805	ERJ-6GEYJ470V	Panasonic
26	1	R9	6.8 Ω , 5%, 1/10 W, Metal Film, 0603	ERJ-3GEYJ685V	Panasonic
27	1	R11	22 Ω , 5%, 1/4 W, Metal Film, 1206	ERJ-8GEYJ220V	Panasonic
28	1	R13	560 Ω , 5%, 1/10 W, Metal Film, 0603	ERJ-3GEYJ561V	Panasonic
29	1	R15	1 k Ω , 5%, 1/10 W, Metal Film, 0603	ERJ-3GEYJ102V	Panasonic
30	1	R16	15 k Ω , 1%, 1/16 W, Metal Film, 0603	ERJ-3EKF1502V	Panasonic
31	1	R17	3.92 k Ω , 1%, 1/16 W, Metal Film, 0603	ERJ-3EKF3921V	Panasonic
32	1	R23	75 k Ω , 5%, 1/10 W, Metal Film, 0603	ERJ-3GEYJ753V	Panasonic
33	1	T1	Bobbin, RM6_S/I, Vertical, 8 pins w 2 pin clip	CPV-RM6S/I-1S-8PD	Ferroxcube
34	1	U1	TOP264VG, eDIP-12P	TOP264VG	Power Integrations
35	1	U2	IC, REG ZENER SHUNT ADJ SOT-23	LM431AIM3/NOPB	National Semiconductor
36	1	U3	Optocoupler, 80 V, CTR 80-160%, 4-Mini Flat	PC357N4J00F	Sharp
37	1	VR1	15 V, 5%, 500 mW, SOD-323	BZT52C155-7	Diodes Inc



7 Transformer Specification

7.1 Electrical Diagram

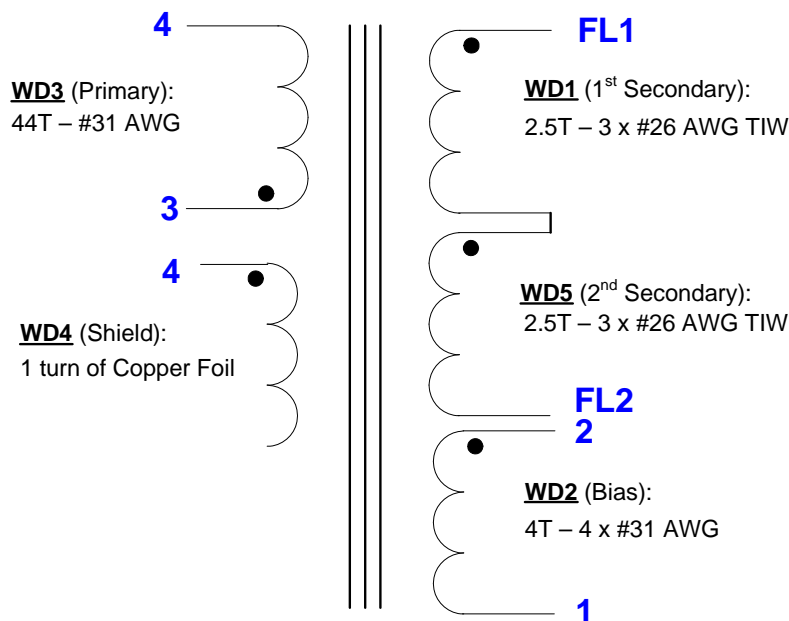

Figure 5 – Transformer Electrical Diagram.

7.2 Electrical Specifications

Parameter	Condition	Specification
Electrical Strength	1 second, 60 Hz, from pins 1-4 to pins FL1–FL2	3000 VAC
Primary Inductance	Pins 3-4, all other windings open, measured at 132 kHz, 0.4 VRMS	650 μ H, \pm 5%
Resonant Frequency	Pins 3- 4, all other windings open	1 MHz (Min.)
Primary Leakage Inductance	Pins 3-4, with pins FL1–FL2 shorted, measured at 132 kHz, 0.4 VRMS	10 μ H (Max.)

7.3 Materials

Item	Description
[1]	Core: RM6 / PC90 or PC95 AL: 2700 nH/T ² .
[2]	Bobbin: RM6, Vertical, 8 pins (4/4).
[3]	Magnet wire: #31 AWG (double coated).
[4]	Magnet wire: #26 AWG – Triple Insulated Wire.
[5]	Cooper Foil Tape: 2 mils thick, 6 mm wide, to be attached with tape item [7]. (see Figure 7).
[6]	Tape: 3M 1298 Polyester Film, 6 mm wide.
[7]	Tape: 3M 1298 Polyester Film, 10 mm wide.



7.4 Transformer Build Diagram

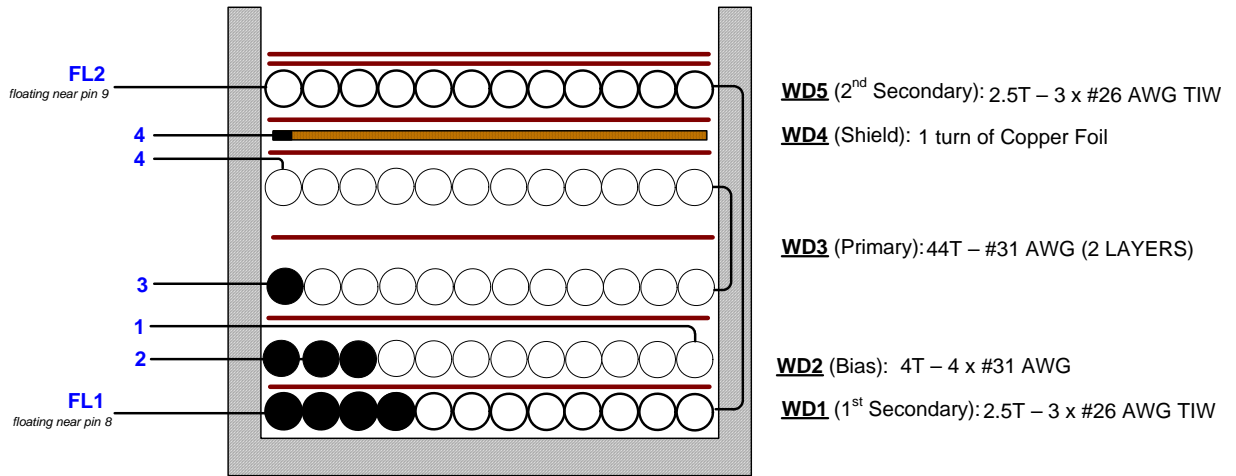

Figure 6 – Transformer Build Diagram.

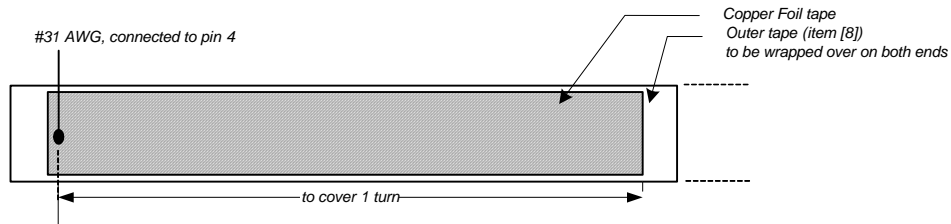

Figure 7 – Copper Foil Tape.



7.5 Transformer Construction

Bobbin Preparation	Position the bobbin on the mandrel so pin side on the right hand side. Winding direction is clockwise direction.
WD1 1st Secondary	Leave start end about 1 inch at pin 9 position for FL1, wind 2.5 bifilar turns of item [5] from right to left and let the remaining wires hanging to the leftmost of the bobbin. Note that the remaining wires will be used in WD5.
Insulation	1 layer of tape item [6].
WD2 Bias	Start at pin 2, wind 4 trifilar turns of item [3] from right to left, spread the wires evenly on the bobbin, and bring the wires back to the left to terminate at pin 1.
Insulation	1 layer of tape item [6].
WD3 Primary	Start at pin 3, wind 22 turns of item [3], from right to left for the first layer, then from left to right 22 turns for second layer, terminate at pin 4. (Total for this winding is 44 turns). Put one turn of tape in between the layers.
Insulation	1 layer of tape item [6].
WD4 Shield	Apply item [6] for 1 turn and should be overlapped.
Insulation	1 layer of tape item [6].
WD5 2nd Secondary	Continue winding the remaining wires from WD1 for 2.5 turns and leave 1 inch near pin 9.
Insulation	2 layer of tape item [6].
Finish	Grind cores to get 650 μ H inductance. Assemble and secure the cores with tape. Dip varnish



8 Common Mode Choke Specification (L1)

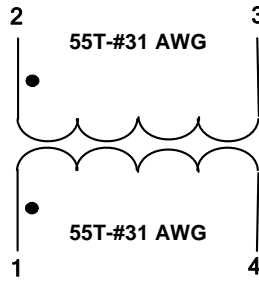

Figure 8 – CMC Electrical Diagram.

8.1 Electrical Specifications

Inductance (LCM)	Pins 1-4 or 2-3. measured at 100 kHz	8 mH \pm 10%
Leakage (LL)	Pins 1-4 with pins 2-3 shorted or versa at 100 kHz	80 μ H (Max.) \pm 20%
Core Effective Inductance		4400 nH/N ²

8.2 Materials

Item	Description
[1]	Toroid Core: AMIDON FT-50-43; Dimension: OD:0.5 in / ID:0.281 in / HT: 0.188 in.
[2]	Magnet Wire: #31 AWG, Heavy Nyleze.

8.3 Winding instructions

- Use 4 ft of item [2], start at pin 1 wind 55 turns end at pin 4.
- Do the same for another half of Toroid, start at pin 2 and end at pin 3.

8.4 Illustrations

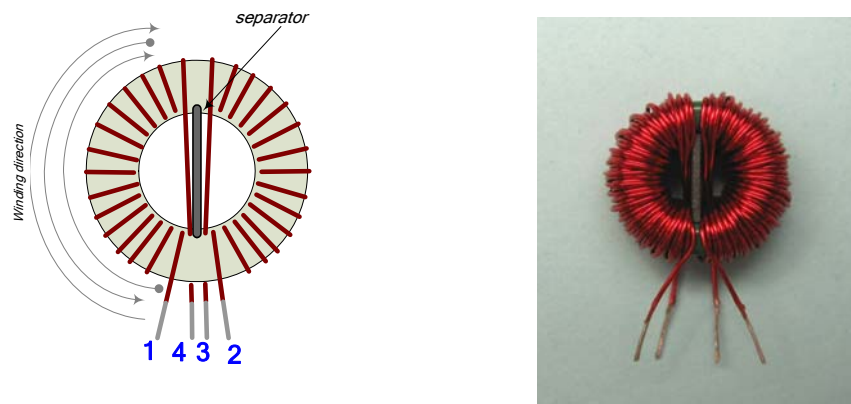

Figure 9 – CMC Build Illustration.



9 Transformer Design Spreadsheet

ACDC_TOPSwitchJX_020110; Rev.1.2; Copyright Power Integrations 2010		INPUT	INFO	OUTPUT	UNIT	TOP_JX_020110: TOPSwitch-JX Continuous/Discontinuous Flyback Transformer Design Spreadsheet
ENTER APPLICATION VARIABLES						
VACMIN	90				Volts	Minimum AC Input Voltage
VACMAX	265				Volts	Maximum AC Input Voltage
fL	50				Hertz	AC Mains Frequency
VO	12.00				Volts	Output Voltage (main)
PO_AVG	18.00				Watts	Average Output Power
PO_PEAK				18.00	Watts	Peak Output Power
Heatsink Type	External			External		Heatsink Type
Enclosure	Adapter					Open Frame enclosure assume sufficient airflow while adapter means a sealed enclosure.
n	0.85				%/100	Efficiency Estimate
Z	0.50					Loss Allocation Factor
VB	11	<i>Info</i>			Volts	Ensure proper operation at no load.
tC	3.00				ms	Bridge Rectifier Conduction Time Estimate
CIN	32.0			32	uFarads	Input Filter Capacitor
ENTER TOPSWITCH-JX VARIABLES						
TOPSwitch-JX	TOP264V				Universal / Peak	115 Doubled/230V
<i>Chosen Device</i>		<i>TOP264V</i>	Power Out		20 W / 43 W	30W
KI	0.65					External Ilimit reduction factor (KI=1.0 for default ILIMIT, KI <1.0 for lower ILIMIT)
ILIMITMIN_EXT			0.786		Amps	Use 1% resistor in setting external ILIMIT
ILIMITMAX_EXT			0.904		Amps	Use 1% resistor in setting external ILIMIT
Frequency (F)=132kHz, (H)=66kHz	F		F			Select 'H' for Half frequency - 66kHz, or 'F' for Full frequency - 132kHz
fS			132000		Hertz	TOPSwitch-JX Switching Frequency: Choose between 132 kHz and 66 kHz
fSmin			119000		Hertz	TOPSwitch-JX Minimum Switching Frequency
fSmax			145000		Hertz	TOPSwitch-JX Maximum Switching Frequency
High Line Operating Mode			FF			Full Frequency, Jitter enabled
VOR	110.00				Volts	Reflected Output Voltage
VDS			10		Volts	TOPSwitch on-state Drain to Source Voltage
VD	0.50				Volts	Output Winding Diode Forward Voltage Drop
VDB	0.70				Volts	Bias Winding Diode Forward Voltage Drop
KP	0.85					Ripple to Peak Current Ratio (0.3 < KRP < 1.0 : 1.0 < KDP < 6.0)
PROTECTION FEATURES						
LINE SENSING						V pin functionality
VUV_STARTUP			101		Volts	Minimum DC Bus Voltage at which the power supply will start-up



VOV_SHUTDO WN			490	Volts	Typical DC Bus Voltage at which power supply will shut-down (Max)
RLS			4.4	M-ohms	Use two standard, 2.2 M-Ohm, 5% resistors in series for line sense functionality.
OUTPUT OVERVOLTAGE					
VZ			20	Volts	Zener Diode rated voltage for Output Overvoltage shutdown protection
RZ			5.1	k-ohms	Output OVP resistor. For latching shutdown use 20 ohm resistor instead
OVERLOAD POWER LIMITING					
Overload Current Ratio at VMAX			1.2		Enter the desired margin to current limit at VMAX. A value of 1.2 indicates that the current limit should be 20% higher than peak primary current at VMAX
Overload Current Ratio at VMIN			1.05		Margin to current limit at low line.
ILIMIT_EXT_VMIN			0.74	A	Peak primary Current at VMIN
ILIMIT_EXT_VMAX			0.76	A	Peak Primary Current at VMAX
RIL			9.76	k-ohms	Current limit/Power Limiting resistor.
RPL			N/A	M-ohms	Resistor not required. Use RIL resistor only
ENTER TRANSFORMER CORE/CONSTRUCTION VARIABLES					
Core Type	RM6		RM6		Core Type
Core		#N/A		P/N:	#N/A
Bobbin		#N/A		P/N:	#N/A
AE	0.3750		0.375	cm^2	Core Effective Cross Sectional Area
LE	2.1800		2.18	cm	Core Effective Path Length
AL	2700.0		2700	nH/T^2	Ungapped Core Effective Inductance
BW	6.3		6.3	mm	Bobbin Physical Winding Width
M	0.00			mm	Safety Margin Width (Half the Primary to Secondary Creepage Distance)
L	2.00				Number of Primary Layers
NS			5		Number of Secondary Turns
DC INPUT VOLTAGE PARAMETERS					
VMIN			83	Volts	Minimum DC Input Voltage
VMAX			375	Volts	Maximum DC Input Voltage
CURRENT WAVEFORM SHAPE PARAMETERS					
DMAX			0.60		Maximum Duty Cycle (calculated at PO_PEAK)
I AVG			0.25	Amps	Average Primary Current (calculated at average output power)
IP			0.74	Amps	Peak Primary Current (calculated at Peak output power)
IR			0.63	Amps	Primary Ripple Current (calculated at average output power)
IRMS			0.36	Amps	Primary RMS Current (calculated at average output power)
TRANSFORMER PRIMARY DESIGN PARAMETERS					
LP			651	uHenries	Primary Inductance
LP Tolerance	5		5		Tolerance of Primary Inductance
NP			44		Primary Winding Number of Turns
NB			5		Bias Winding Number of Turns
ALG			336	nH/T^2	Gapped Core Effective Inductance



BM			2909	Gauss	Maximum Flux Density at PO, VMIN (BM<3000)
BP			3748	Gauss	Peak Flux Density (BP<4200) at ILIMITMAX and LP_MAX. Note: Recommended values for adapters and external power supplies <=3600 Gauss
BAC			1236	Gauss	AC Flux Density for Core Loss Curves (0.5 X Peak to Peak)
ur			1249		Relative Permeability of Ungapped Core
LG			0.12	mm	Gap Length (Lg > 0.1 mm)
BWE			12.6	mm	Effective Bobbin Width
OD			0.29	mm	Maximum Primary Wire Diameter including insulation
INS			0.05	mm	Estimated Total Insulation Thickness (= 2 * film thickness)
DIA			0.24	mm	Bare conductor diameter
AWG			31	AWG	Primary Wire Gauge (Rounded to next smaller standard AWG value)
CM			81	Cmils	Bare conductor effective area in circular mils
CMA			226	Cmils/Amp	Primary Winding Current Capacity (200 < CMA < 500)
Primary Current Density (J)			8.89	Amps/mm ²	Primary Winding Current density (3.8 < J < 9.75)
TRANSFORMER SECONDARY DESIGN PARAMETERS (SINGLE OUTPUT EQUIVALENT)					
Lumped parameters					
ISP			6.48	Amps	Peak Secondary Current
ISRMS			2.56	Amps	Secondary RMS Current
IO_PEAK			1.50	Amps	Secondary Peak Output Current
IO			1.50	Amps	Average Power Supply Output Current
IRIPPLE			2.08	Amps	Output Capacitor RMS Ripple Current
CMS			513	Cmils	Secondary Bare Conductor minimum circular mils
AWGS			23	AWG	Secondary Wire Gauge (Rounded up to next larger standard AWG value)
DIAS			0.58	mm	Secondary Minimum Bare Conductor Diameter
ODS			1.26	mm	Secondary Maximum Outside Diameter for Triple Insulated Wire
INSS			0.34	mm	Maximum Secondary Insulation Wall Thickness
VOLTAGE STRESS PARAMETERS					
VDRAIN			593	Volts	Maximum Drain Voltage Estimate (Includes Effect of Leakage Inductance)
PIVS			55	Volts	Output Rectifier Maximum Peak Inverse Voltage
PIVB			51	Volts	Bias Rectifier Maximum Peak Inverse Voltage
TRANSFORMER SECONDARY DESIGN PARAMETERS (MULTIPLE OUTPUTS)					
1st output					
VO1			12	Volts	Output Voltage
IO1_AVG			1.50	Amps	Average DC Output Current
PO1_AVG			18.00	Watts	Average Output Power
VD1			0.5	Volts	Output Diode Forward Voltage Drop
NS1			5.00		Output Winding Number of Turns
ISRMS1			2.563	Amps	Output Winding RMS Current
IRIPPLE1			2.08	Amps	Output Capacitor RMS Ripple Current
PIVS1			55	Volts	Output Rectifier Maximum Peak Inverse Voltage
CMS1			513	Cmils	Output Winding Bare Conductor minimum circular mils
AWGS1			23	AWG	Wire Gauge (Rounded up to next larger standard AWG value)



DIAS1			0.58	mm	Minimum Bare Conductor Diameter
ODS1			1.26	mm	Maximum Outside Diameter for Triple Insulated Wire
2nd output					
VO2				Volts	Output Voltage
IO2_AVG				Amps	Average DC Output Current
PO2_AVG			0.00	Watts	Average Output Power
VD2			0.7	Volts	Output Diode Forward Voltage Drop
NS2			0.28		Output Winding Number of Turns
ISRMS2			0.000	Amps	Output Winding RMS Current
IRIPPLE2			0.00	Amps	Output Capacitor RMS Ripple Current
PIVS2			2	Volts	Output Rectifier Maximum Peak Inverse Voltage
CMS2			0	Cmils	Output Winding Bare Conductor minimum circular mils
AWGS2			N/A	AWG	Wire Gauge (Rounded up to next larger standard AWG value)
DIAS2			N/A	mm	Minimum Bare Conductor Diameter
ODS2			N/A	mm	Maximum Outside Diameter for Triple Insulated Wire
3rd output					
VO3				Volts	Output Voltage
IO3_AVG				Amps	Average DC Output Current
PO3_AVG			0.00	Watts	Average Output Power
VD3			0.7	Volts	Output Diode Forward Voltage Drop
NS3			0.28		Output Winding Number of Turns
ISRMS3			0.000	Amps	Output Winding RMS Current
IRIPPLE3			0.00	Amps	Output Capacitor RMS Ripple Current
PIVS3			2	Volts	Output Rectifier Maximum Peak Inverse Voltage
CMS3			0	Cmils	Output Winding Bare Conductor minimum circular mils
AWGS3			N/A	AWG	Wire Gauge (Rounded up to next larger standard AWG value)
DIAS3			N/A	mm	Minimum Bare Conductor Diameter
ODS3			N/A	mm	Maximum Outside Diameter for Triple Insulated Wire
Total Continuous Output Power			18	Watts	Total Continuous Output Power
Negative Output			N/A		If negative output exists enter Output number; eg: If VO2 is negative output, enter 2



10 Mechanical Drawings

The following mechanical drawings are for the custom mechanical designs used in this power supply.

10.1 TOP264VG (U1) Heatsink

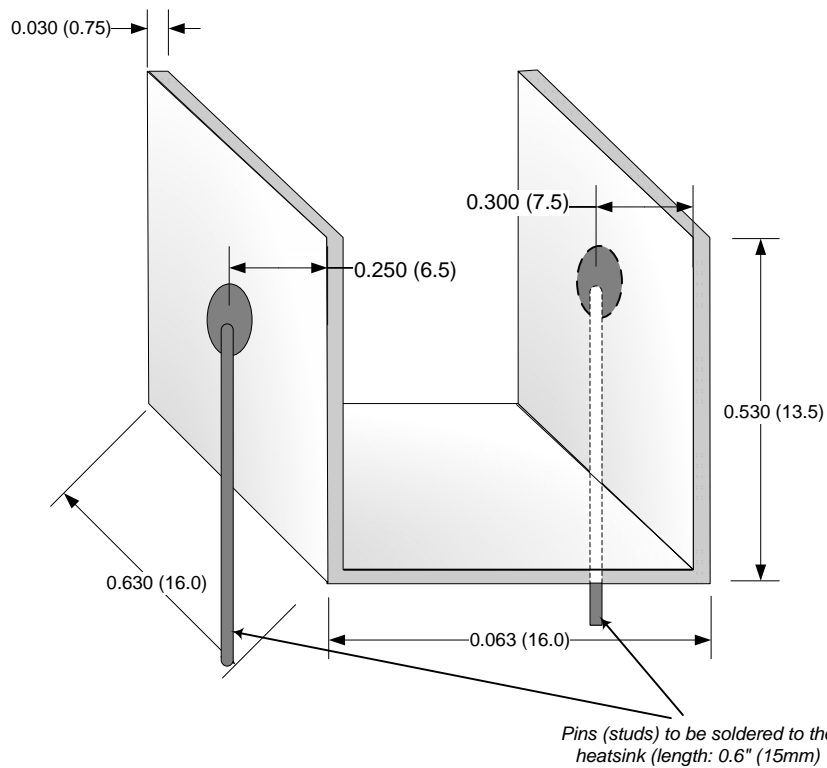

<ul style="list-style-type: none"> - Company: Power Integration - Job Title: DER237 – Diode heatsink - Revision: 3 - Location: - Drawn by: LN Date: 01/12/2010 - Pl#: 61-00030-02 	<ul style="list-style-type: none"> - Material: Solderable steel - Thickness: 0.020" (0.5mm). - Unit measurement: in/mm. - Tolerance: +/- 0.010 (0.2). - Note: Do not scale the drawing.
--	---

Figure 10 – U1 Heatsink.



10.2 Output Diode (D8) Heatsink

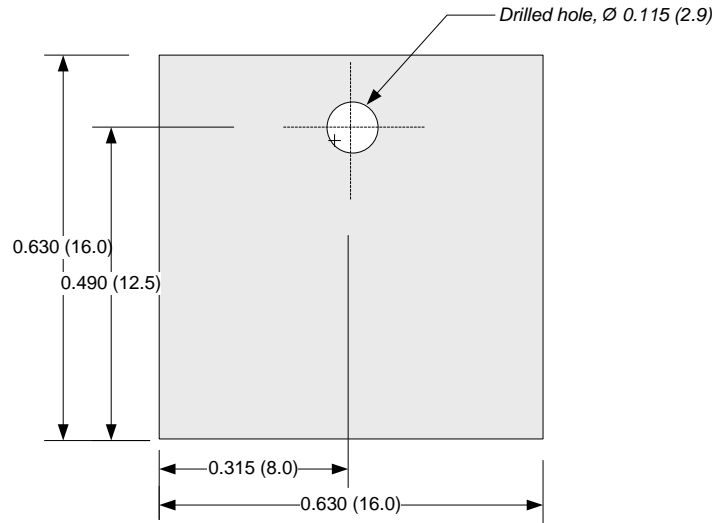

[Heat sink for Diode](#)

<ul style="list-style-type: none"> - Company: Power Integration - Job Title: DER237 – Diode heatsink - Revision: 2 - Location: - Drawn by: LN Date: 09/25/2009 - Pl#: 61-00029-01 	<ul style="list-style-type: none"> - Material: Al, 3003. - Thickness: 0.030" (0.75mm). - Unit measurement: in/mm. - Tolerance: +/- 0.010 (0.2). - Note: Do not scale the drawing.
--	---

Figure 11 – D8 Heatsink.



11 Performance Data

All tests were performed at room temperature with 90 V / 50 Hz, 115 V / 60 Hz, 230 V / 50 Hz, and 265 V / 50 Hz line input voltages and corresponding frequencies unless otherwise noted. The power supply was put in a plastic case and allowed to warm up for 30 minutes at full load. The input was provided via a 1 meter AC cable. The output was measured at the end of a 1.8 meter #22 AWG cable.

11.1 Full Load Efficiency

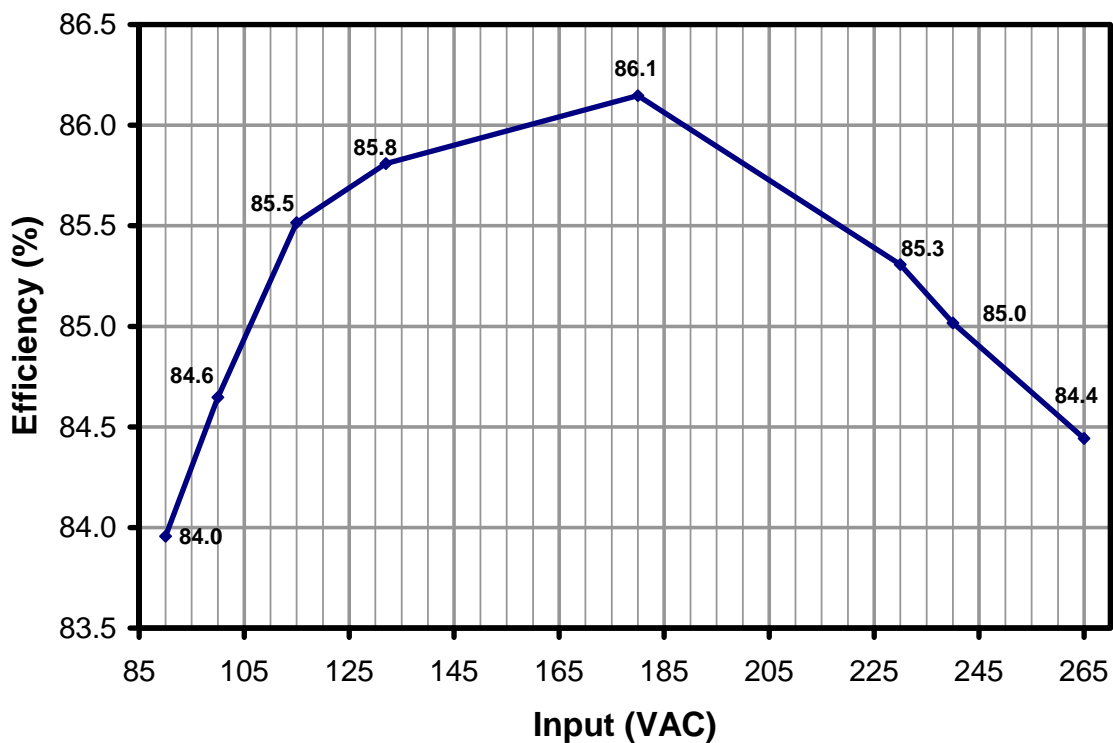

Figure 12 – Efficiency vs. Input Voltage, Room Temperature, 60 Hz.



11.2 Active Mode Efficiency

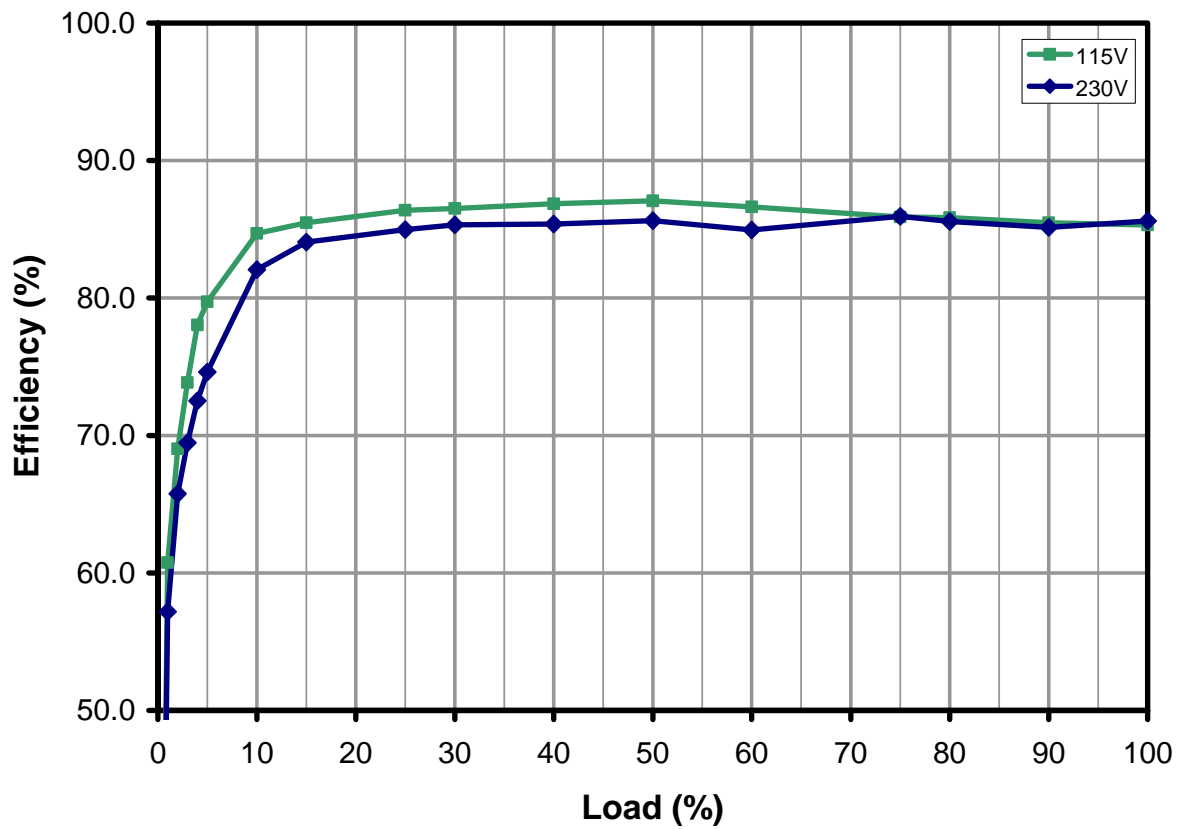

Figure 13 – Efficiency vs. Load.



Percent of Full Load	Efficiency (%)	
	115 VAC	230 VAC
1	60.8	57.2
2	69.0	65.8
3	73.8	69.5
4	78.0	72.5
5	79.7	74.6
10	84.7	82.1
15	85.5	84.1
25	86.4	85.0
30	86.5	85.3
40	86.9	85.4
50	87.1	85.6
60	86.6	85.0
75	85.9	85.9
80	85.9	85.6
90	85.5	85.1
100	85.3	85.6
Average	86.16	85.54
US EISA (2007) requirement	76	
ENERGY STAR EPS v2, EC CoC v4, EUP Tier 2	80	

11.3 Energy Efficiency Requirements

The external power supply requirements below all require meeting active mode efficiency and no-load input power limits. Minimum active mode efficiency is defined as the average efficiency of 25, 50, 75 and 100% of output current (based on the nameplate output current rating).

For adapters that are single input voltage only then the measurement is made at the rated single nominal input voltage (115 VAC or 230 VAC), for universal input adapters the measurement is made at both nominal input voltages (115 VAC and 230 VAC).

To meet the standard the measured average efficiency (or efficiencies for universal input supplies) must be greater than or equal to the efficiency specified by the standard.

The test method can be found here:

http://www.energystar.gov/ia/partners/prod_development/downloads/power_supplies/EP_SupplyEffic_TestMethod_0804.pdf

For the latest up to date information please visit the PI Green Room:

<http://www.powerint.com/greenroom/regulations.htm>



11.3.1 USA Energy Independence and Security Act 2007

This legislation mandates all single output single output adapters, including those provided with products, manufactured on or after July 1st, 2008 must meet minimum active mode efficiency and no load input power limits.

Active Mode Efficiency Standard Models

Nameplate Output (P_o)	Minimum Efficiency in Active Mode of Operation
< 1 W	$0.5 \times P_o$
≥ 1 W to ≤ 51 W	$0.09 \times \ln(P_o) + 0.5$
> 51 W	0.85

Ln = natural logarithm

No-load Energy Consumption

Nameplate Output (P_o)	Maximum Power for No-load AC-DC EPS
All	≤ 0.5 W

This requirement supersedes the legislation from individual US States (for example CEC in California).

11.3.2 ENERGY STAR EPS Version 2.0

This specification takes effect on November 1st, 2008.

Active Mode Efficiency Standard Models

Nameplate Output (P_o)	Minimum Efficiency in Active Mode of Operation
≤ 1 W	$0.48 \times P_o + 0.14$
> 1 W to ≤ 49 W	$0.0626 \times \ln(P_o) + 0.622$
> 49 W	0.87

ln = natural logarithm

Active Mode Efficiency Low Voltage Models ($V_o < 6$ V and $I_o \geq 550$ mA)

Nameplate Output (P_o)	Minimum Efficiency in Active Mode of Operation
≤ 1 W	$0.497 \times P_o + 0.067$
> 1 W to ≤ 49 W	$0.075 \times \ln(P_o) + 0.561$
> 49 W	0.86

ln = natural logarithm

No-load Energy Consumption (both models)

Nameplate Output (P_o)	Maximum Power for No-load AC-DC EPS
0 to < 50 W	≤ 0.3 W
≥ 50 W to ≤ 250 W	≤ 0.5 W



11.4 No-load Input Power

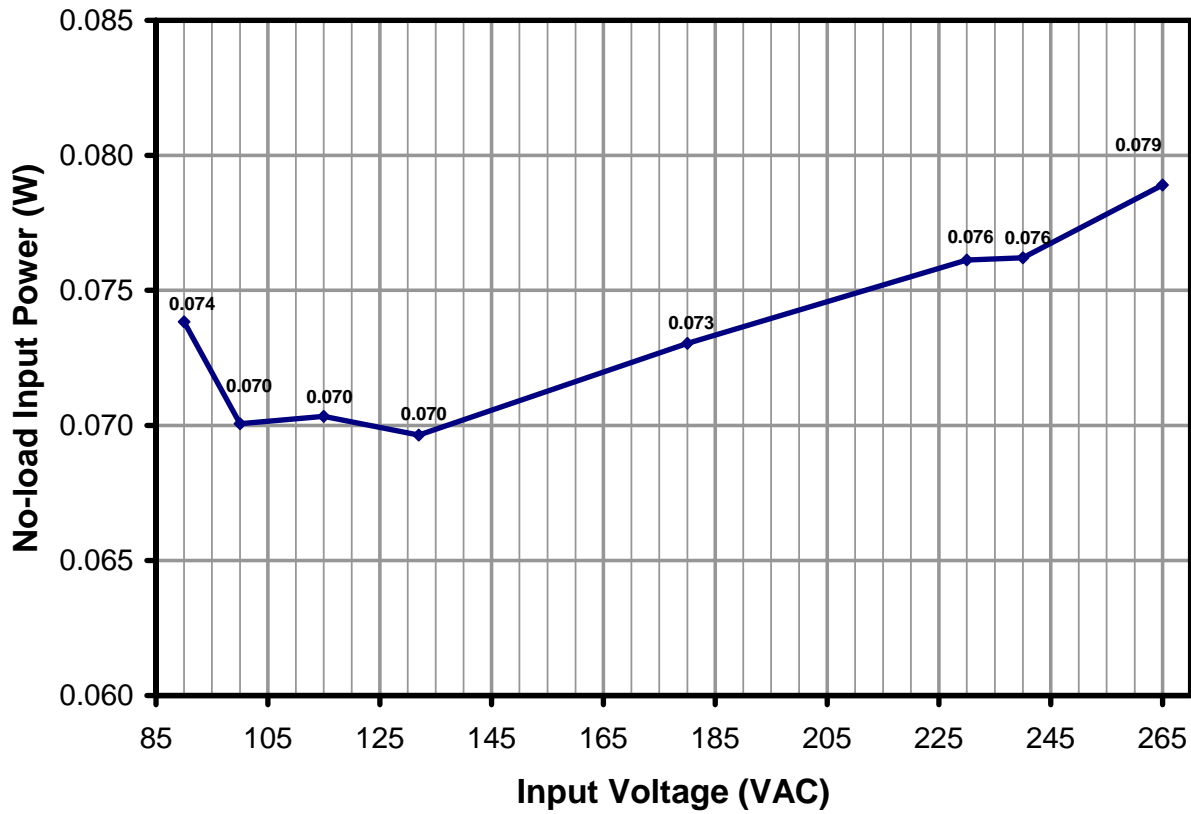

Figure 14 – Zero Load Input Power vs. Input Line Voltage, Room Temperature.



11.5 Available Standby Output Power

The chart below shows the available output power vs line voltage for an input power of 1 W, 2 W and 3 W.

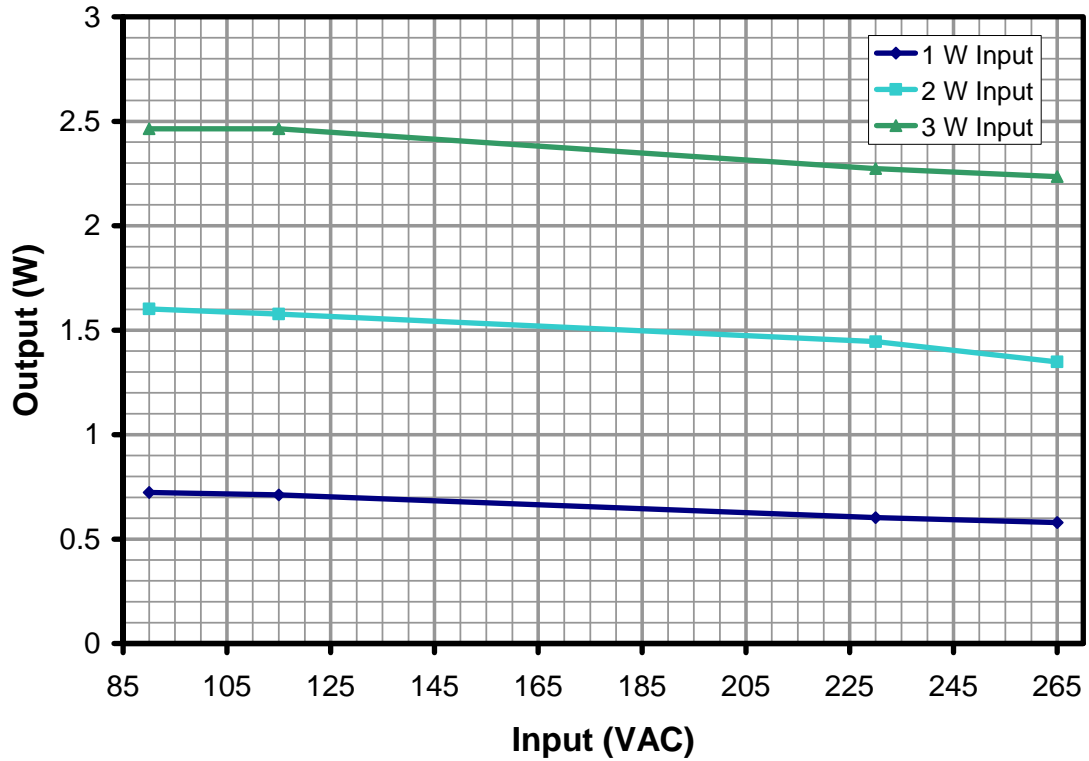

Figure 15 – Available Standby Output Power vs. Input Line Voltage, Room Temperature.



11.6 Regulation

11.6.1 Load

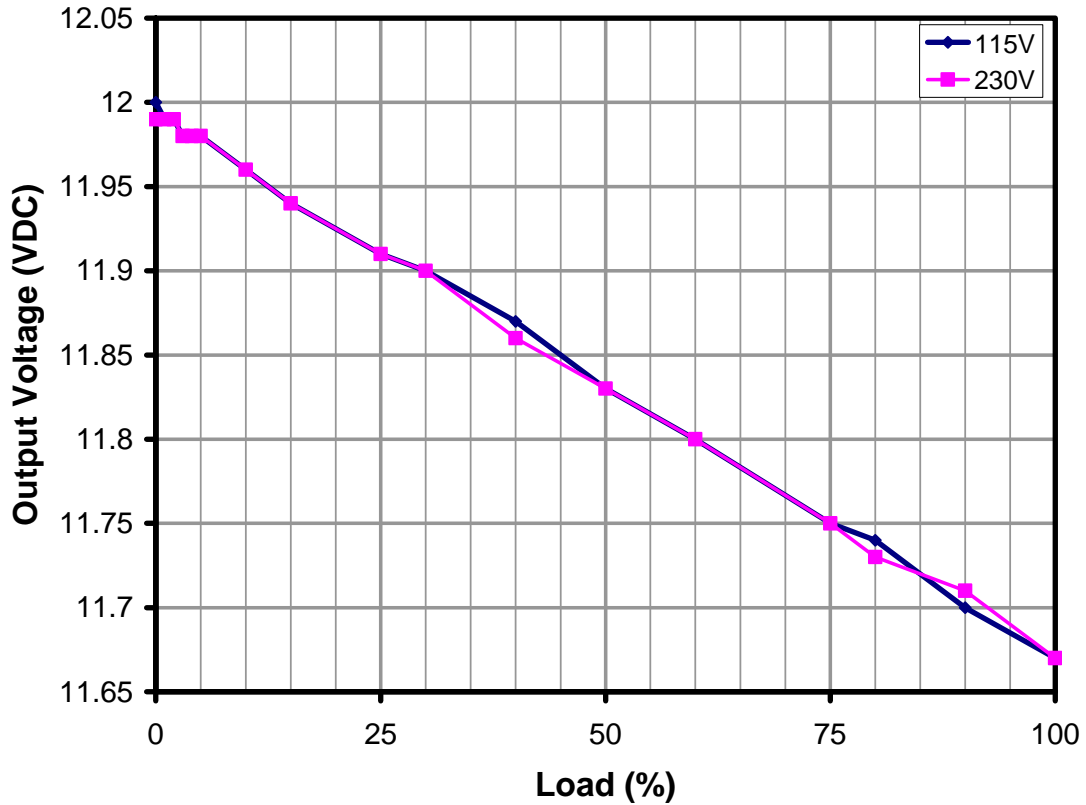

Figure 16 – Load Regulation, Room Temperature.

Note: Reduction in output voltage with load is due to resistive drop of output cable.



11.6.2 Line

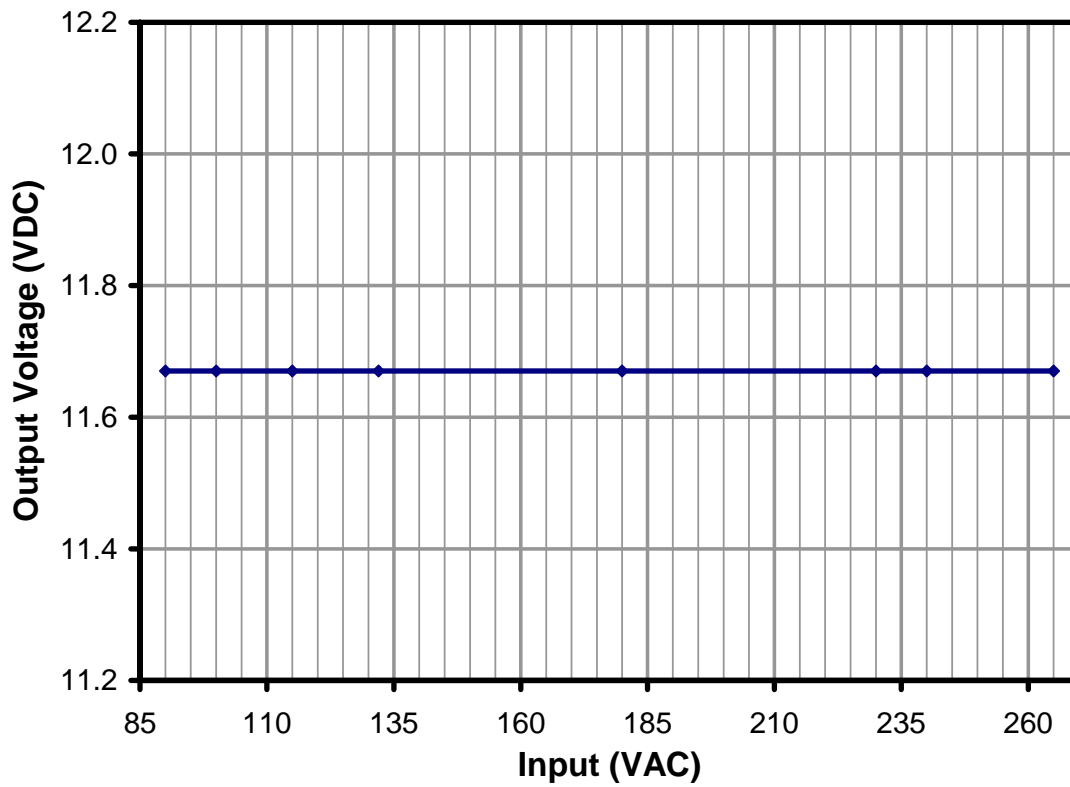

Figure 17 – Line Regulation, Room Temperature, Full Load.



12 Thermal Performance

The power supply was placed inside a plastic case and sealed, without potting material. The supply was heated, with no airflow, for at least two hours and measurements were taken immediately.

For reliability testing, the power supply went through a burn-in cycle, which involved running it at full load inside an oven for 12 hours in a 40 °C ambient temperature condition at maximum load. The unit did not at any time go into thermal shutdown.

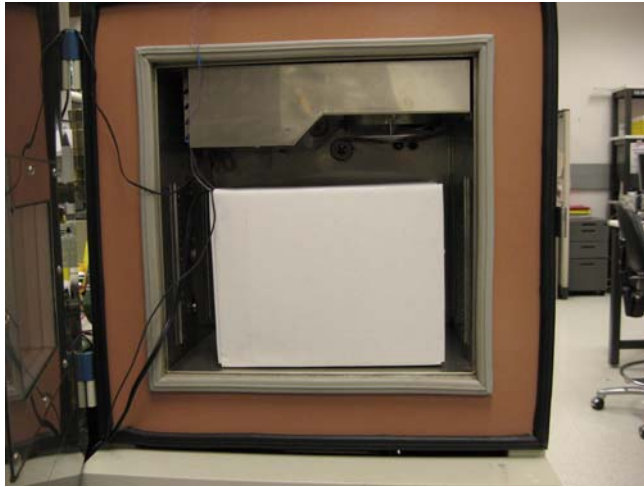

Figure 18 – Carton Box, with Power Supply Adapter Inside, Placed in Oven for Burn-in.

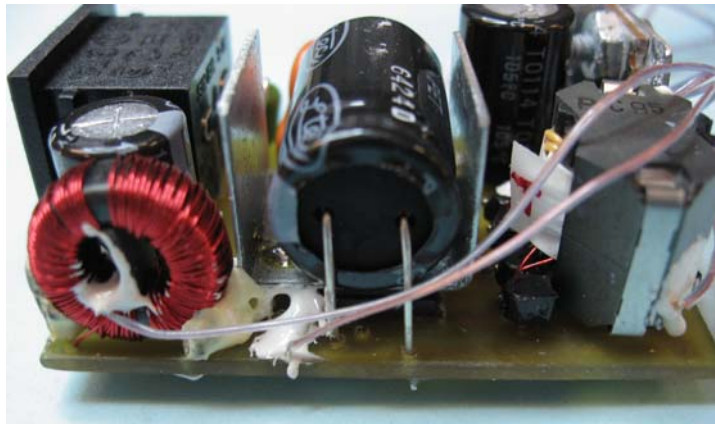

Figure 19 – Thermocouple on CMC and IC SOURCE Pin.



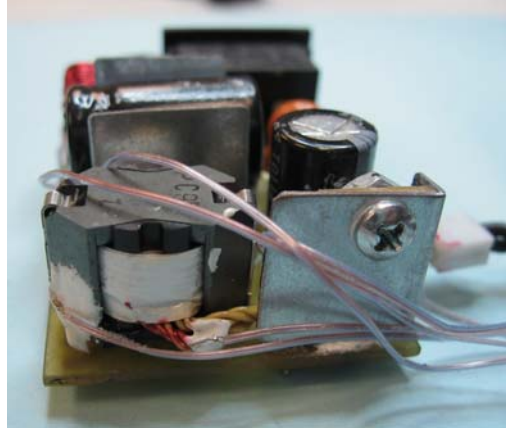

Figure 20 – Thermocouple on Transformer Core, Transformer Winding, Output Diode.

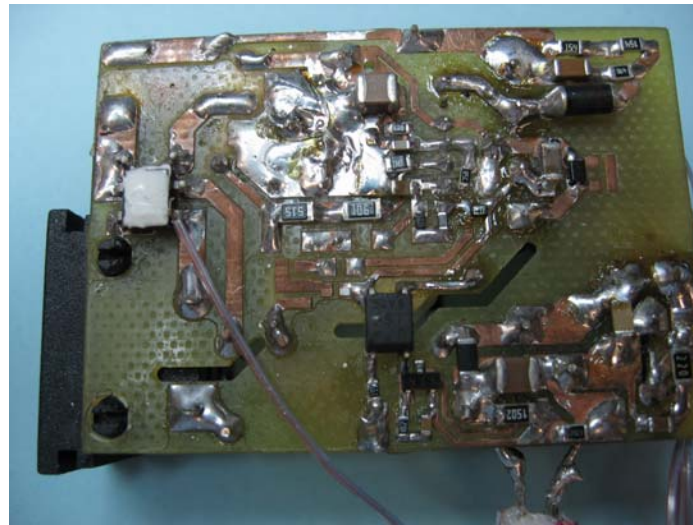

Figure 21 – Thermocouple on Bridge Rectifier.

18 W, 12 V	Temperature (°C)			
	90 VAC	115 VAC	230 VAC	265 VAC
Ambient	40.0	40.0	40.0	40.0
TRF winding	91	92	98	103
TRF core	100	101	109	116
Output rectifier body	98	98	103	109
Bridge	91	82	72	73
IC SOURCE pin	104	95	89	96
CMC	88	81	72	74
Case internal ambient	73	69	66	69



13 Waveforms

13.1 Drain Voltage and Current, Normal Operation

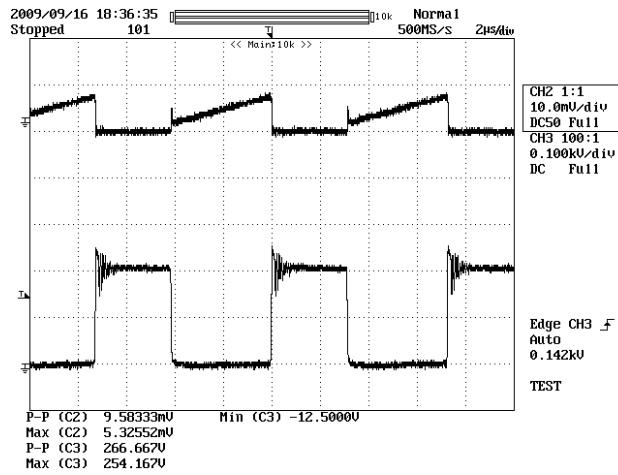

Figure 22 – 85 VAC, 50Hz Full Load.
Upper: I_{DRAIN} , 0.5 A / div.
Lower: V_{DRAIN} , 100 V, 2 μ s / div.

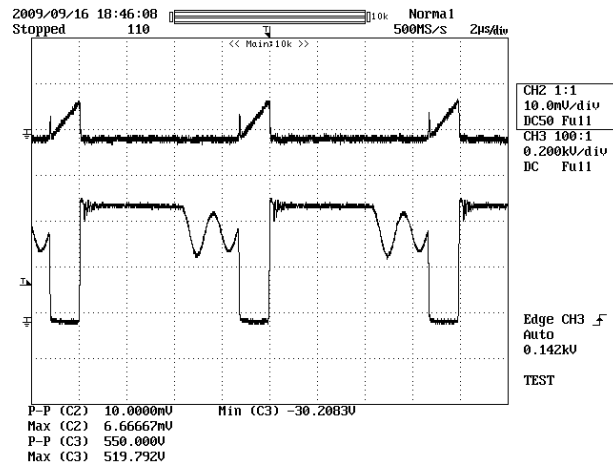

Figure 23 – 265 VAC, Full Load.
Upper: I_{DRAIN} , 0.5 A / div.
Lower: V_{DRAIN} , 200 V / div.

13.2 Output Voltage Start-up Profile

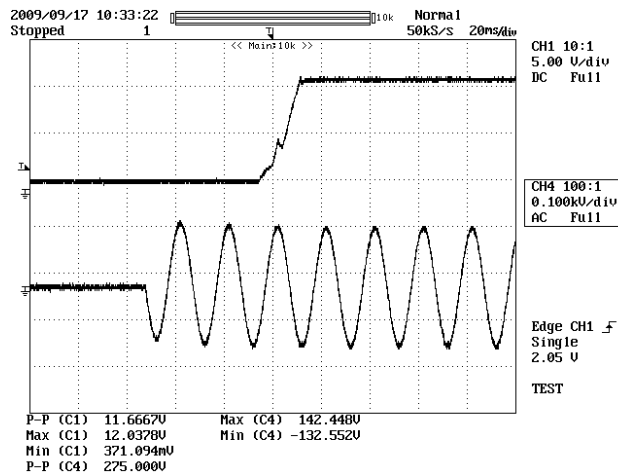

Figure 24 – Start-up Profile, 90 VAC, 50 Hz
20 ms / div.
Upper: V_{IN} , 100 V / div.
Lower: V_{OUT} , 2 V / div.

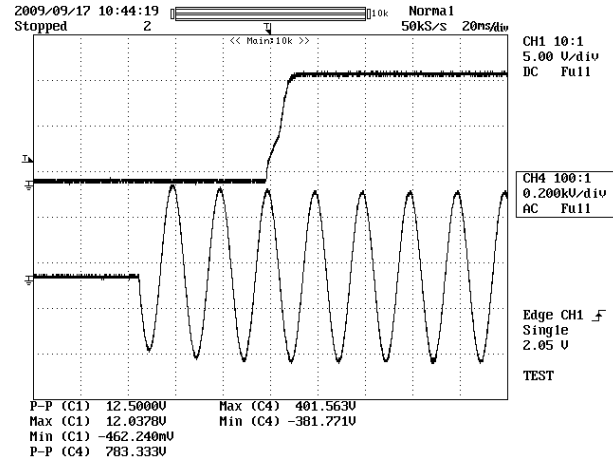

Figure 25 – Start-up Profile, 265 VAC, 50 Hz
20 ms / div.
Upper: V_{IN} , 200 V / div.
Lower: V_{OUT} , 2 V / div.

Note: Slope change in V_{OUT} in Figure 24 was due to electronic load used for testing and does not occur with resistive loads.



13.3 Drain Voltage and Current Start-up Profile

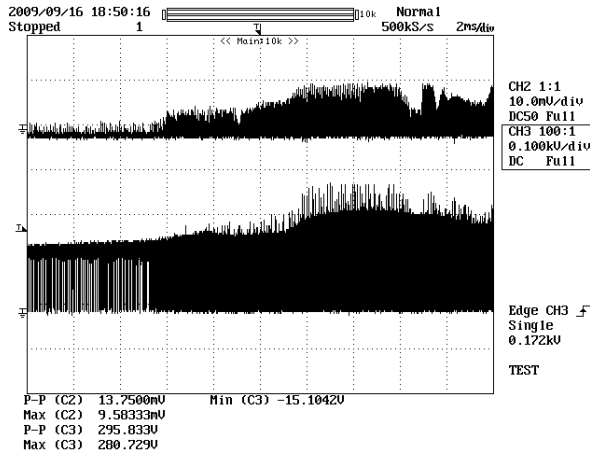

Figure 26 – 85 VAC Input and Maximum Load.
Upper: I_{DRAIN} , 0.5 A / div.
Lower: V_{DRAIN} , 100 V & 1 ms / div.

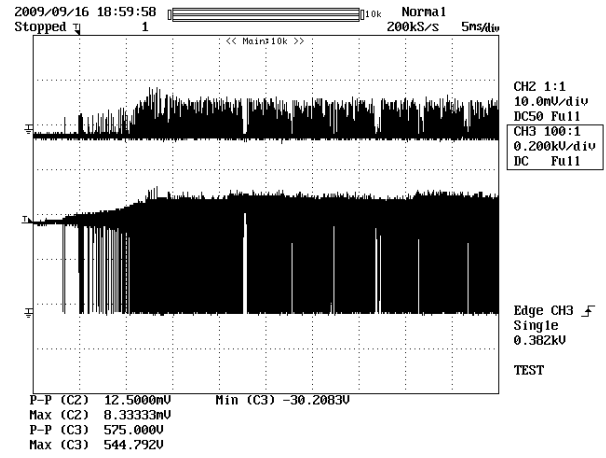

Figure 27 – 265 VAC Input and Maximum Load.
Upper: I_{DRAIN} , 0.5 A / div.
Lower: V_{DRAIN} , 200 V & 1 ms / div.

13.4 Output Diode Peak Inverse Voltage

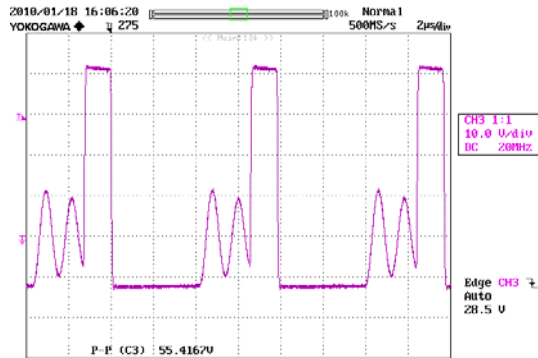

Figure 28 – 265 VAC; 12 V Output 1.5 A Load.
2 μ s, 10 V / div.



13.5 Load Transient Response (75% to 100% Load Step)

In the figures shown below, signal averaging was used to better enable viewing the load transient response. The oscilloscope was triggered using the load current step as a trigger source. Since the output switching and line frequency occur essentially at random with respect to the load transient, contributions to the output ripple from these sources will average out, leaving the contribution only from the load step response. Note the DC shifts are due to the output cable resistance.

Measurements taken with 68 μ F capacitive load on the output to dampen noise.

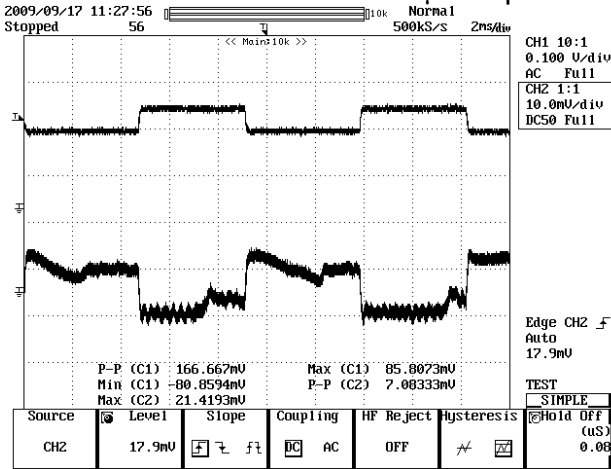

Figure 29 – Transient Response, 90 VAC, 50 Hz
75-100-75% Load Step.
Upper: Load Current, 1 A / div.
Lower: Output Voltage
50 mV, 500 μ s / div.

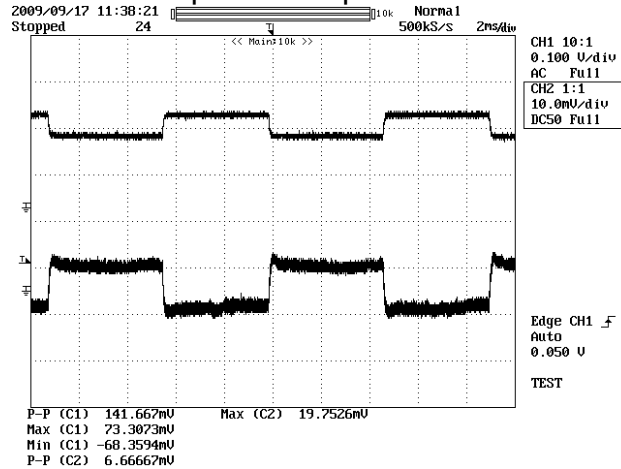

Figure 30 – Transient Response, 265 VAC,
75-100-75% Load Step.
Upper: Load Current, 1 A / div.
Lower: Output Voltage
50 mV, 2 ms / div.



13.6 Output Ripple Measurements

13.6.1 Ripple Measurement Technique

For DC output ripple measurements, a modified oscilloscope test probe must be utilized in order to reduce spurious signals due to pickup. Details of the probe modification are provided in the figures below.

The 4987BA probe adapter is affixed with two capacitors tied in parallel across the probe tip. The capacitors include one (1) 0.1 $\mu\text{F}/50\text{ V}$ ceramic type and one (1) 1.0 $\mu\text{F}/50\text{ V}$ aluminum electrolytic. The aluminum electrolytic type capacitor is polarized, so proper polarity across DC outputs must be maintained (see below).

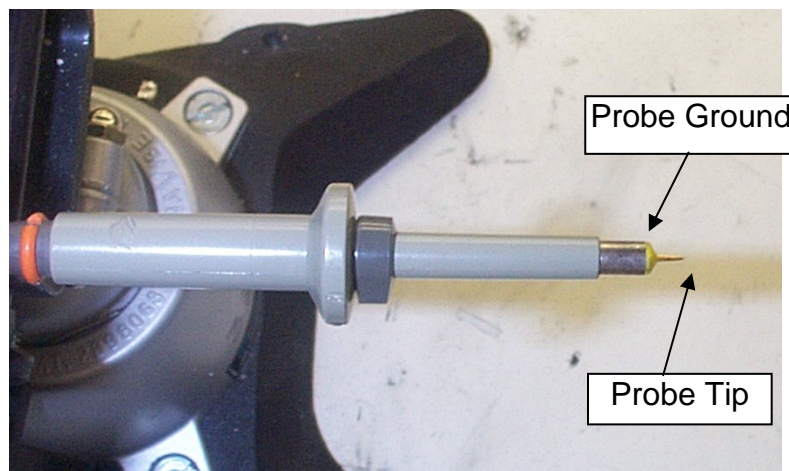

Figure 31 – Oscilloscope Probe Prepared for Ripple Measurement. (End Cap and Ground Lead Removed)



Figure 32 – Oscilloscope Probe with Probe Master (www.probemaster.com) 4987A BNC Adapter. (Modified with wires for ripple measurement, and two parallel decoupling capacitors added)

13.6.2 Measurement Results

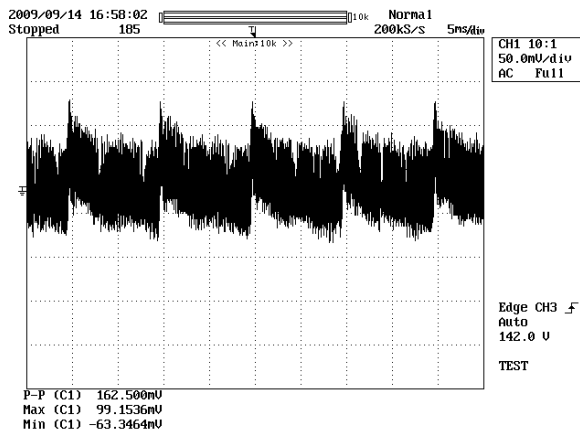

Figure 33 – Ripple, 90 VAC, Full Load.
 5 ms, 20 mV / div.

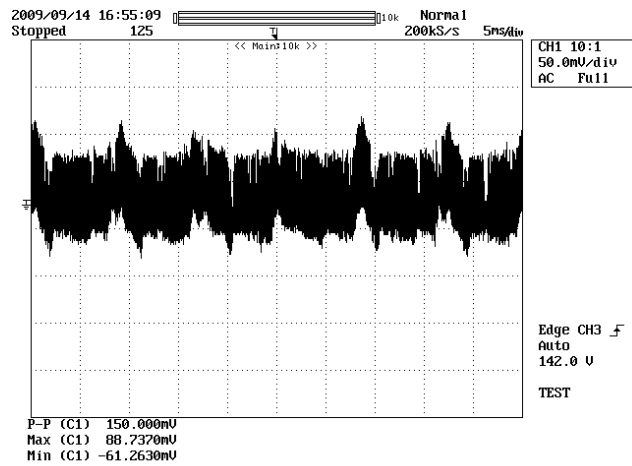

Figure 34 – Ripple, 115 VAC, Full Load.
 5 ms, 20 mV / div.

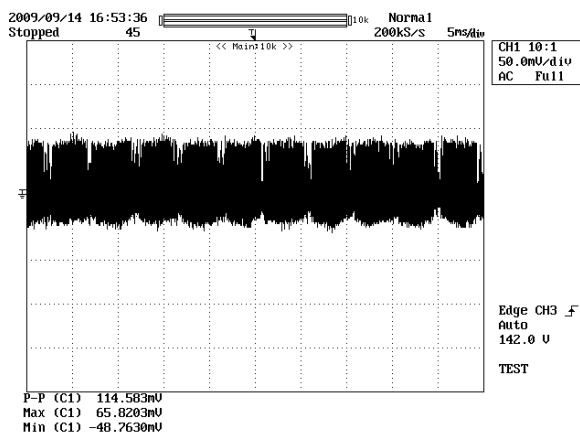

Figure 35 – Ripple, 230 VAC, Full Load.
 5 ms, 20 mV / div.

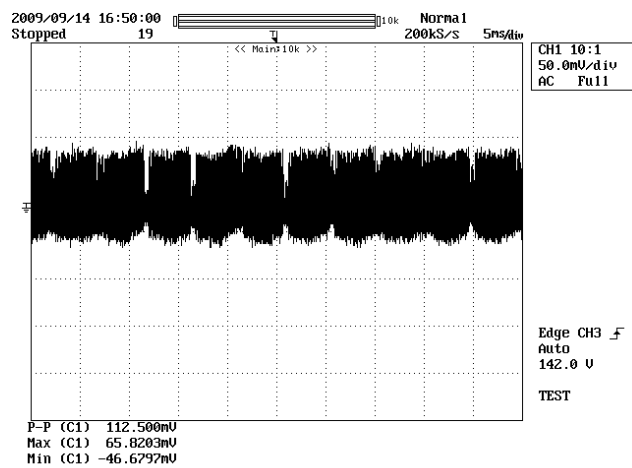

Figure 36 – Ripple, 265 VAC, Full Load.
 5 ms, 20 mV / div.



13.7 Over-voltage Protection

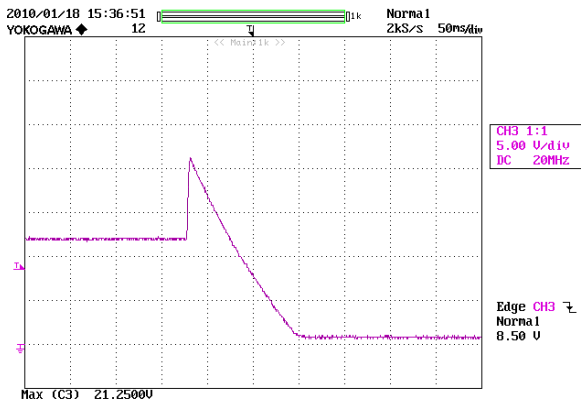

Figure 37 – 115 VAC; 12 V Output 100 mA Load.
50 ms, 5 V / div.

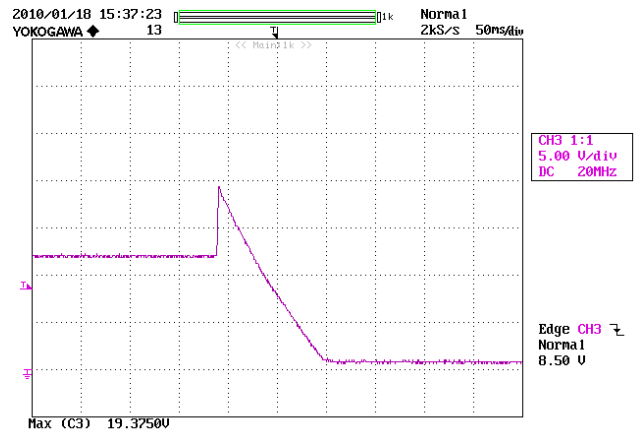

Figure 38 – 230 VAC; 12 V Output 100 mA Load.
50 ms, 5 V / div.

13.8 Limited Power Source (Over Power Protection)

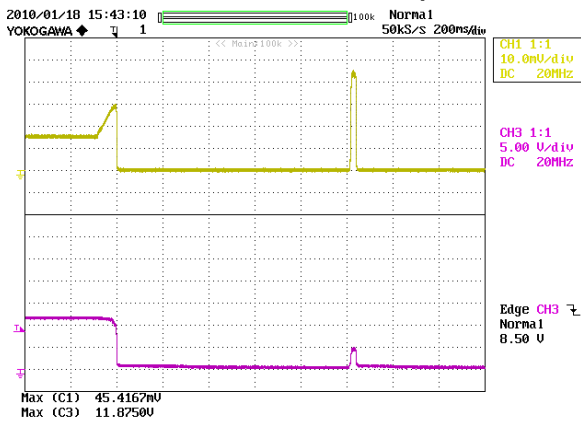

Figure 39 – 90 VAC Input and Maximum Load.
Upper: I_{OUT} , 1 A / div.
Lower: V_{OUT} , 5 V & 200 ms / div.

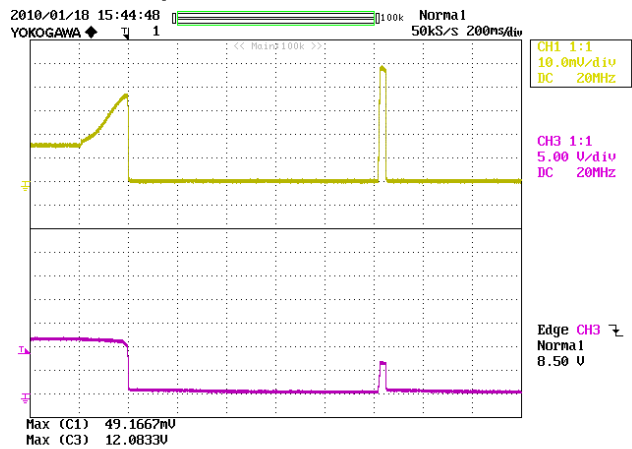

Figure 40 – 265 VAC Input and Maximum Load.
Upper: I_{DRAIN} , 1 A / div.
Lower: V_{DRAIN} , 5 V & 200 ms / div.



13.9 Control Loop Measurements

Venable System equipment was used to gather this data.

13.10 115 VAC Maximum Load

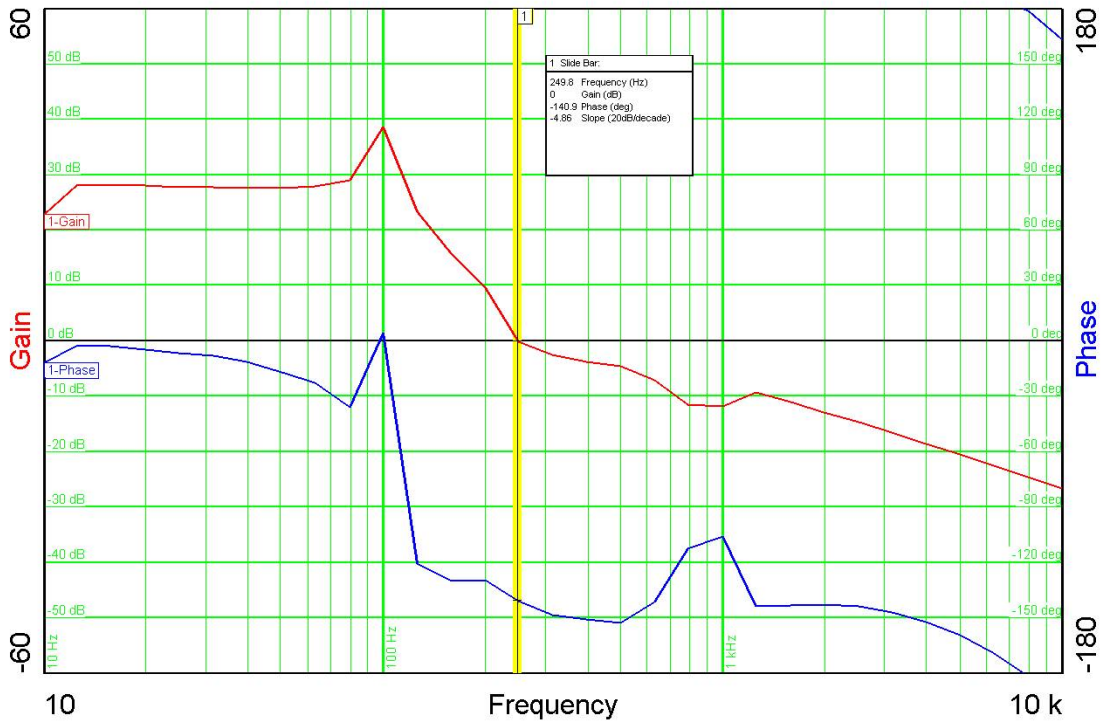

Figure 41 – Gain-Phase Plot, 90 VAC, Maximum Steady State Load.
 Vertical Scale: Gain = 10 dB / div., Phase = 30° / div.
 Crossover Frequency = 249.8 Hz Phase Margin = 49.1°



13.11 230 VAC Maximum Load

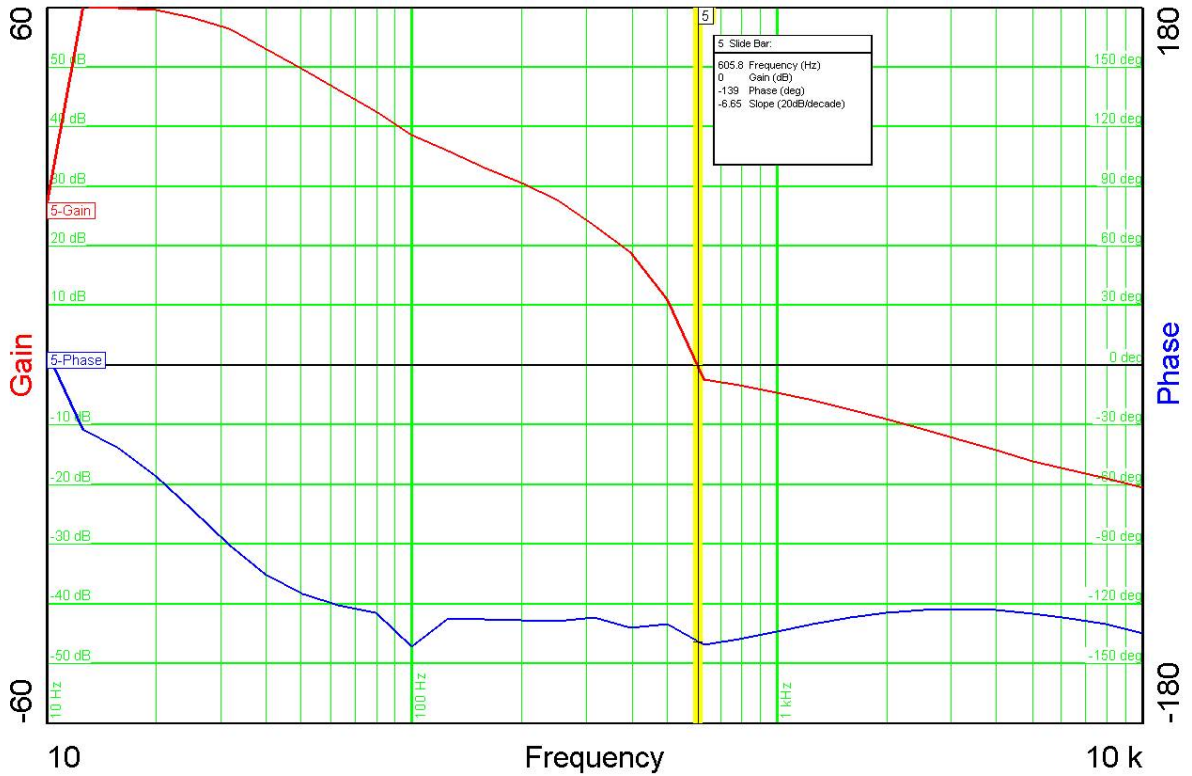

Figure 42 – Gain-Phase Plot, 265 VAC, Maximum Steady State Load.
Vertical Scale: Gain = 10 dB / div., Phase = 30° / div.
Crossover Frequency = 605.8 Hz, Phase Margin = 41°



14 Conducted EMI

Equipment used: Rohde and Schwarz ESPI3 (PN: m1142.8007.03 / EMI Test Receiver 9 kHz to 3 GHz).

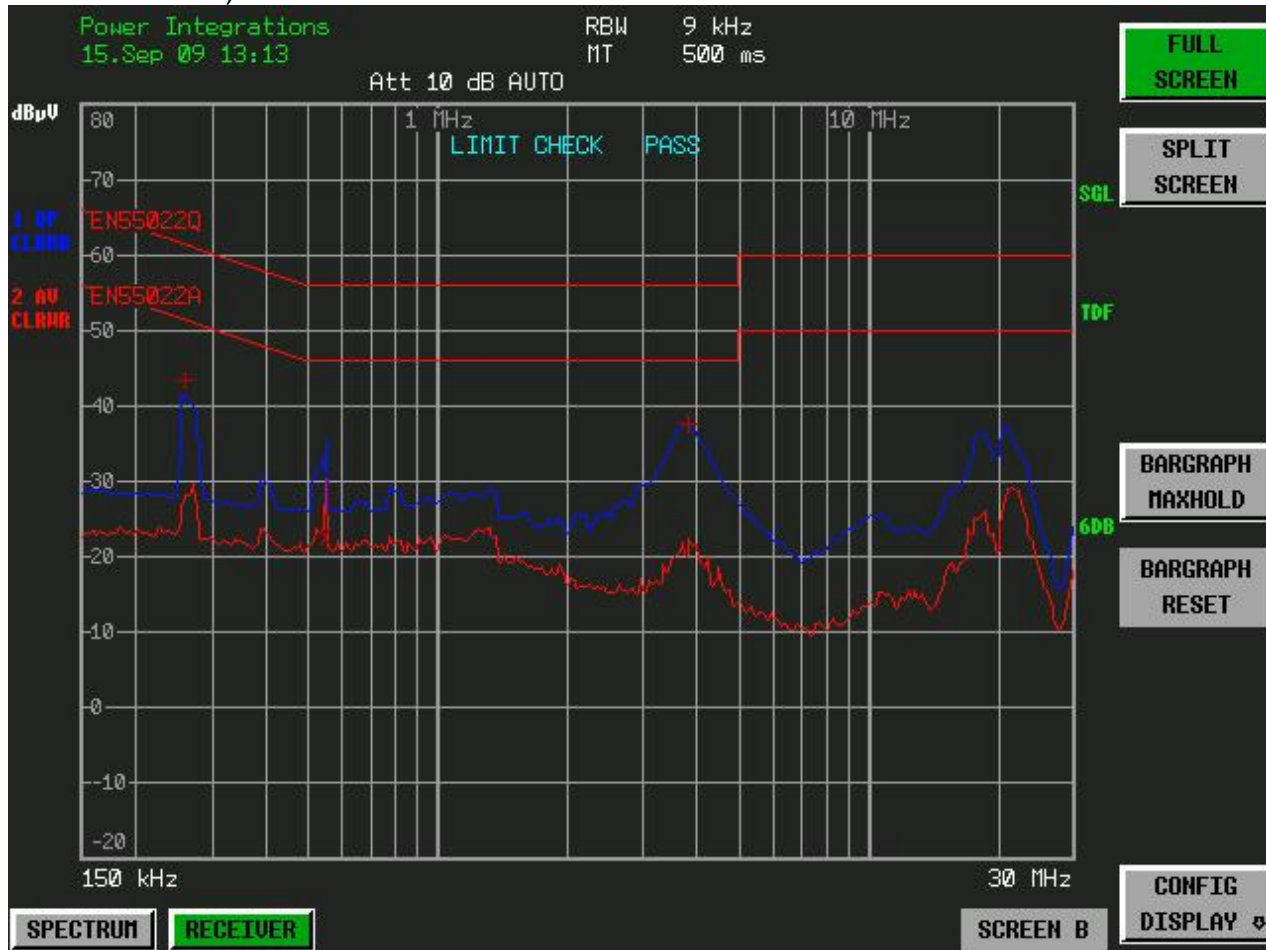

Figure 43 – Conducted EMI, Maximum Steady State Load, 115 VAC, 60 Hz, and EN55022 B Limits. Output Not Connected to PE.

15.Sep 09 13:12 Att 10 dB AUTO RBW 9 kHz MT 500 ms

EDIT PEAK LIST (Final Measurement Results)				
TRACE	FREQUENCY	LEVEL dBµV	DELTA	LIMIT dB
Trace1:	EN55022Q			
Trace2:	EN55022A			
Trace3:	---			
1 Quasi Peak	261.153630926 kHz	43.33	L1 gnd	-18.06
2 Average	554.246035546 kHz	22.69	L1 gnd	-23.30
1 Quasi Peak	3.85939676084 MHz	37.70	N gnd	-18.30

Table 1 – Data for Figure 43.

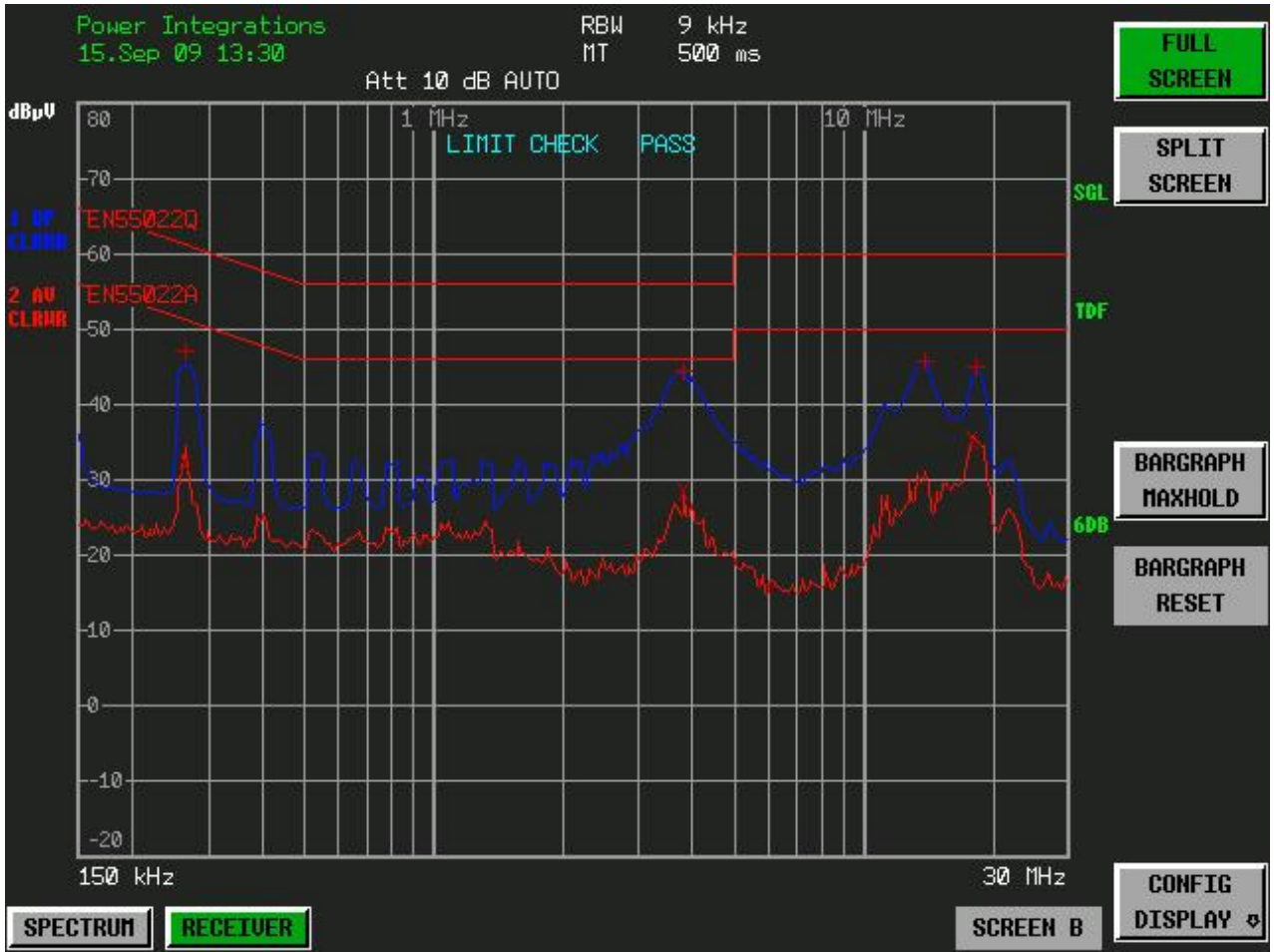

Figure 44 – Conducted EMI, Maximum Steady State Load, 115 VAC, 60 Hz, and EN55022 B Limits. Output Connected to PE.

EDIT PEAK LIST (Final Measurement Results)						
TRACE		FREQUENCY	LEVEL		DELTA	LIMIT
			dBµV		dB	
Trace1:	EN55022Q					
Trace2:	EN55022A					
Trace3:	---					
1	Quasi Peak	266.376703545 kHz	47.16	L1 gnd	-14.06	
2	Average	266.376703545 kHz	32.18	L1 gnd	-19.04	
1	Quasi Peak	3.85939676084 MHz	44.55	N gnd	-11.44	
2	Average	3.85939676084 MHz	28.30	L1 gnd	-17.69	
1	Quasi Peak	13.9807539496 MHz	45.75	L1 gnd	-14.24	
2	Average	18.085596008 MHz	35.26	L1 gnd	-14.73	
1	Quasi Peak	18.4473079281 MHz	44.95	L1 gnd	-15.04	

Table 2 – Data for Figure 44.



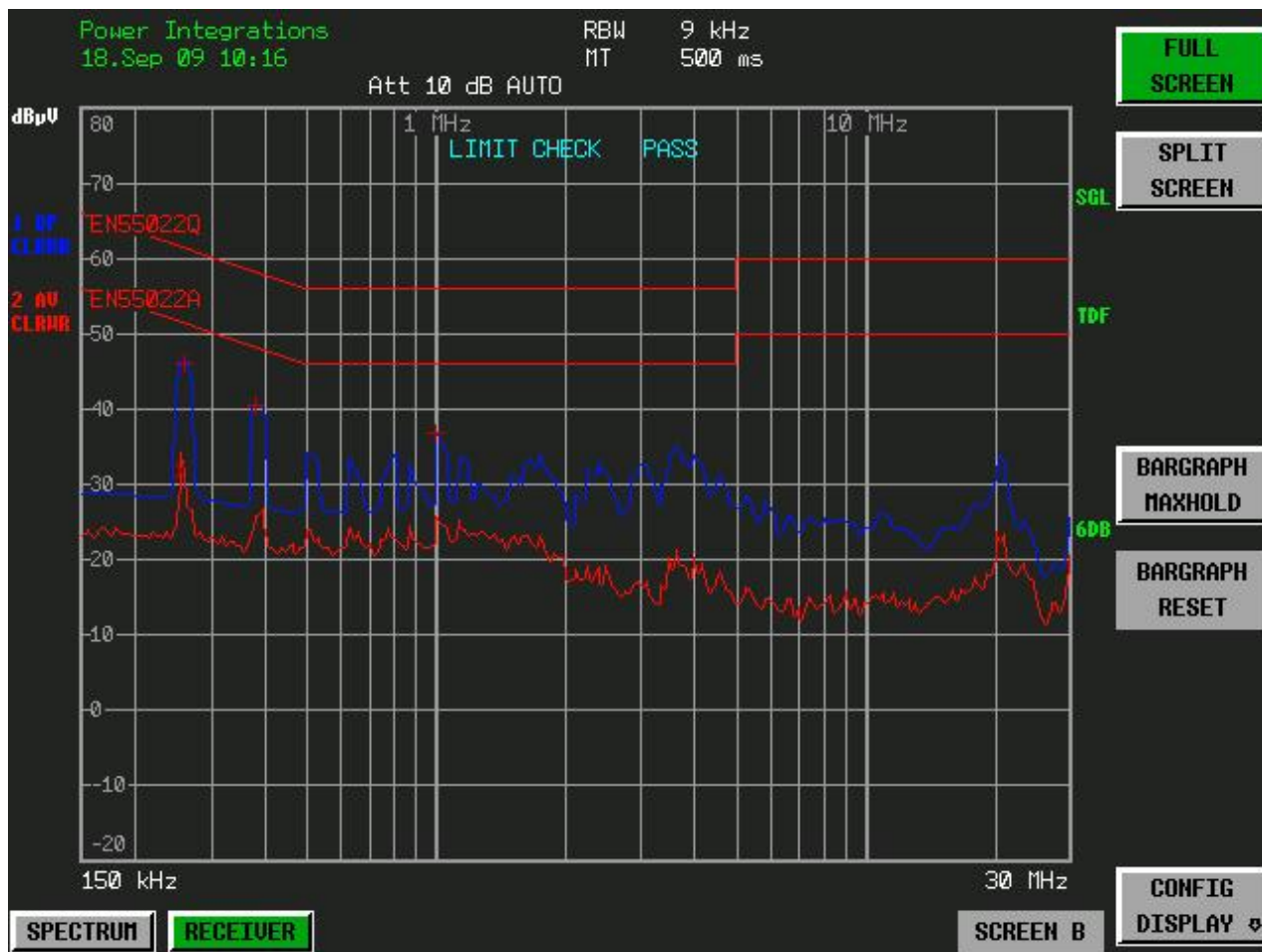

Figure 45 – Conducted EMI, Maximum Steady State Load, 230 VAC, 60 Hz, and EN55022 B Limits. Output Not Connected to PE.

EDIT PEAK LIST (Final Measurement Results)					
TRACE		FREQUENCY	LEVEL	dBµV	DELTA LIMIT
Trace1: EN55022Q					
Trace2: EN55022A					
Trace3: ---					
2	Average	256.032971496 kHz	31.90	N gnd	-19.65
1	Quasi Peak	261.153630926 kHz	45.96	N gnd	-15.42
1	Quasi Peak	380.451527279 kHz	40.45	N gnd	-17.81
1	Quasi Peak	1.00393997693 MHz	36.89	N gnd	-19.11

Table 3 – Data for Figure 45.



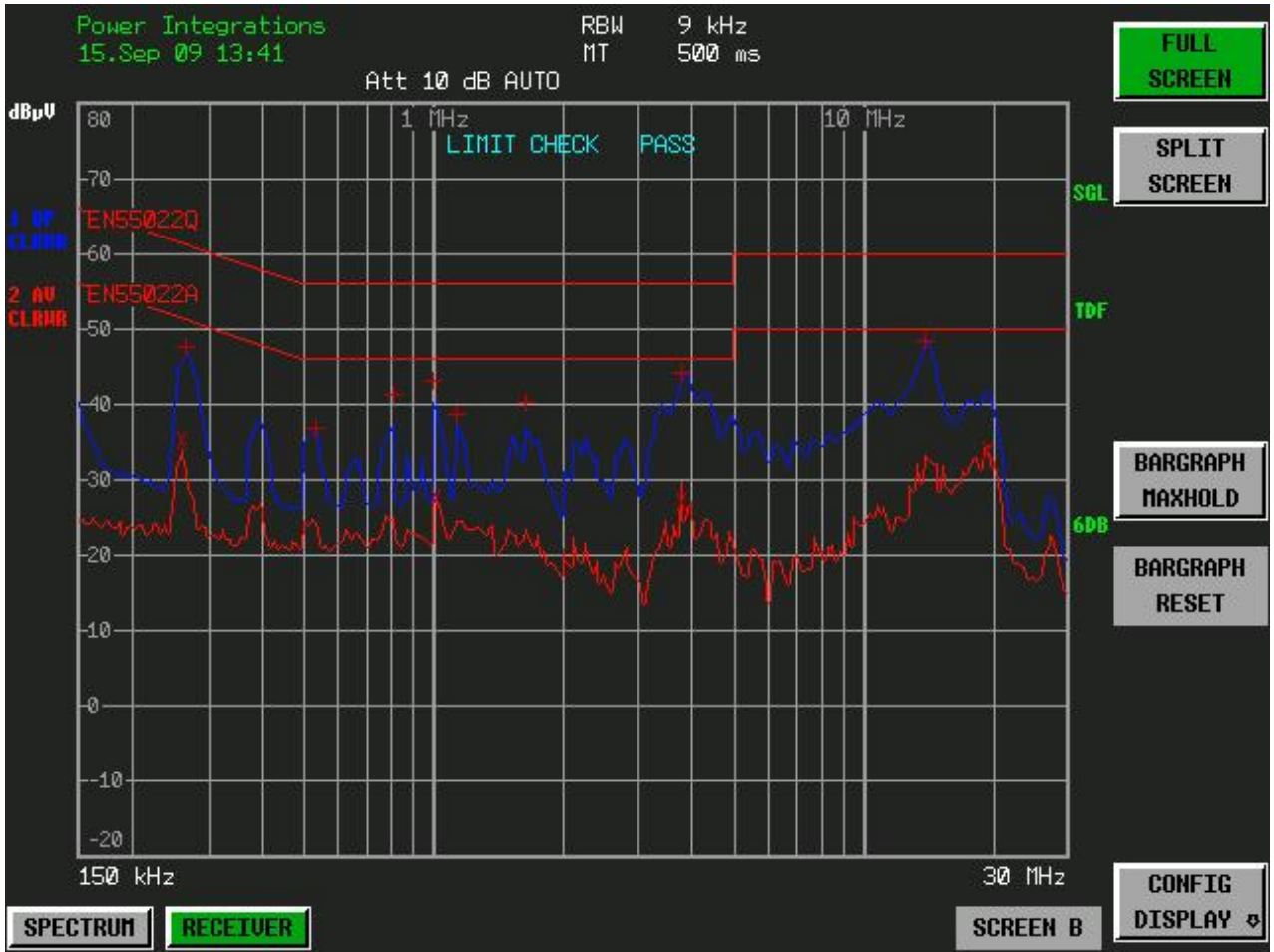

Figure 46 – Conducted EMI, Maximum Steady State Load, 230 VAC, 60 Hz, and EN55022 B Limits. Output Connected to PE.

EDIT PEAK LIST (Final Measurement Results)						
TRACE		FREQUENCY	LEVEL		DELTA	LIMIT
			dBµV			dB
Trace1:	EN55022Q					
Trace2:	EN55022A					
Trace3:	---					
2	Average	261.153630926 kHz	35.21	L1 gnd	-16.18	
1	Quasi Peak	266.376703545 kHz	47.54	L1 gnd	-13.68	
1	Quasi Peak	532.723986492 kHz	36.87	N gnd	-19.13	
1	Quasi Peak	807.431816912 kHz	41.17	L1 gnd	-14.83	
1	Quasi Peak	1.00393997693 MHz	43.24	L1 gnd	-12.75	
2	Average	1.02401877647 MHz	27.57	L1 gnd	-18.42	
1	Quasi Peak	1.13059947321 MHz	38.53	L1 gnd	-17.46	
1	Quasi Peak	1.64706994423 MHz	40.20	L1 gnd	-15.79	
1	Quasi Peak	3.78372231454 MHz	44.21	N gnd	-11.79	
2	Average	3.78372231454 MHz	27.18	N gnd	-18.81	
1	Quasi Peak	13.9807539496 MHz	48.32	L1 gnd	-11.67	
2	Average	19.5764307518 MHz	34.05	L1 gnd	-15.94	

Table 4 – Data for Figure 46.



15 Revision History

Date	Author	Revision	Description & changes	Reviewed
09-Feb-10	ME	1.4	Initial release	Apps & Mktg
19-Mar-15	KM	1.5	Correct WD2 transformer winding information.	



For the latest updates, visit our website: www.power.com

Power Integrations reserves the right to make changes to its products at any time to improve reliability or manufacturability. Power Integrations does not assume any liability arising from the use of any device or circuit described herein. POWER INTEGRATIONS MAKES NO WARRANTY HEREIN AND SPECIFICALLY DISCLAIMS ALL WARRANTIES INCLUDING, WITHOUT LIMITATION, THE IMPLIED WARRANTIES OF MERCHANTABILITY, FITNESS FOR A PARTICULAR PURPOSE, AND NON-INFRINGEMENT OF THIRD PARTY RIGHTS.

PATENT INFORMATION

The products and applications illustrated herein (including transformer construction and circuits' external to the products) may be covered by one or more U.S. and foreign patents, or potentially by pending U.S. and foreign patent applications assigned to Power Integrations. A complete list of Power Integrations' patents may be found at www.power.com. Power Integrations grants its customers a license under certain patent rights as set forth at <http://www.power.com/ip.htm>.

The PI Logo, TOPSwitch, TinySwitch, LinkSwitch, LYTSwitch, InnoSwitch, DPA-Switch, PeakSwitch, CAPZero, SENZero, LinkZero, HiperPFS, HiperTFS, HiperLCS, Ospeed, EcoSmart, Clampless, E-Shield, Filterfuse, FluxLink, StackFET, PI Expert and PI FACTS are trademarks of Power Integrations, Inc. Other trademarks are property of their respective companies. ©Copyright 2015 Power Integrations, Inc.

Power Integrations Worldwide Sales Support Locations

WORLD HEADQUARTERS

5245 Hellyer Avenue
San Jose, CA 95138, USA.
Main: +1-408-414-9200
Customer Service:
Phone: +1-408-414-9665
Fax: +1-408-414-9765
e-mail: usasales@powerint.com

CHINA (SHANGHAI)

Rm 2410, Charity Plaza, No. 88,
North Caoxi Road,
Shanghai, PRC 200030
Phone: +86-21-6354-6323
Fax: +86-21-6354-6325
e-mail: chinasales@powerint.com

CHINA (SHENZHEN)

17/F, Hivac Building, No. 2, Keji
Nan 8th Road, Nanshan District,
Shenzhen, China, 518057
Phone: +86-755-8672-8689
Fax: +86-755-8672-8690
e-mail: chinasales@powerint.com

GERMANY

Lindwurmstrasse 114
80337, Munich
Germany
Phone: +49-895-527-39110
Fax: +49-895-527-39200
e-mail: eurosales@powerint.com

INDIA

#1, 14th Main Road
Vasanthanagar
Bangalore-560052
India
Phone: +91-80-4113-8020
Fax: +91-80-4113-8023
e-mail: indiasales@powerint.com

ITALY

Via Milanese 20, 3rd. Fl.
20099 Sesto San Giovanni
(MI) Italy
Phone: +39-024-550-8701
Fax: +39-028-928-6009
e-mail: eurosales@powerint.com

JAPAN

Kosei Dai-3 Building
2-12-11, Shin-Yokohama,
Kohoku-ku, Yokohama-shi,
Kanagawa 222-0033
Japan
Phone: +81-45-471-1021
Fax: +81-45-471-3717
e-mail: japansales@powerint.com

KOREA

RM 602, 6FL
Korea City Air Terminal B/D,
159-6
Samsung-Dong, Kangnam-Gu,
Seoul, 135-728 Korea
Phone: +82-2-2016-6610
Fax: +82-2-2016-6630
e-mail: koreasales@powerint.com

SINGAPORE

51 Newton Road,
#19-01/05 Goldhill Plaza
Singapore, 308900
Phone: +65-6358-2160
Fax: +65-6358-2015
e-mail: singaporesales@powerint.com

TAIWAN

5F, No. 318, Nei Hu Rd.,
Sec. 1
Nei Hu District
Taipei 11493, Taiwan R.O.C.
Phone: +886-2-2659-4570
Fax: +886-2-2659-4550
e-mail: taiwansales@powerint.com

UK

First Floor, Unit 15, Meadway
Court, Rutherford Close,
Stevenage, Herts. SG1 2EF
United Kingdom
Phone: +44 (0) 1252-730-141
Fax: +44 (0) 1252-727-689
e-mail: eurosales@powerint.com

